

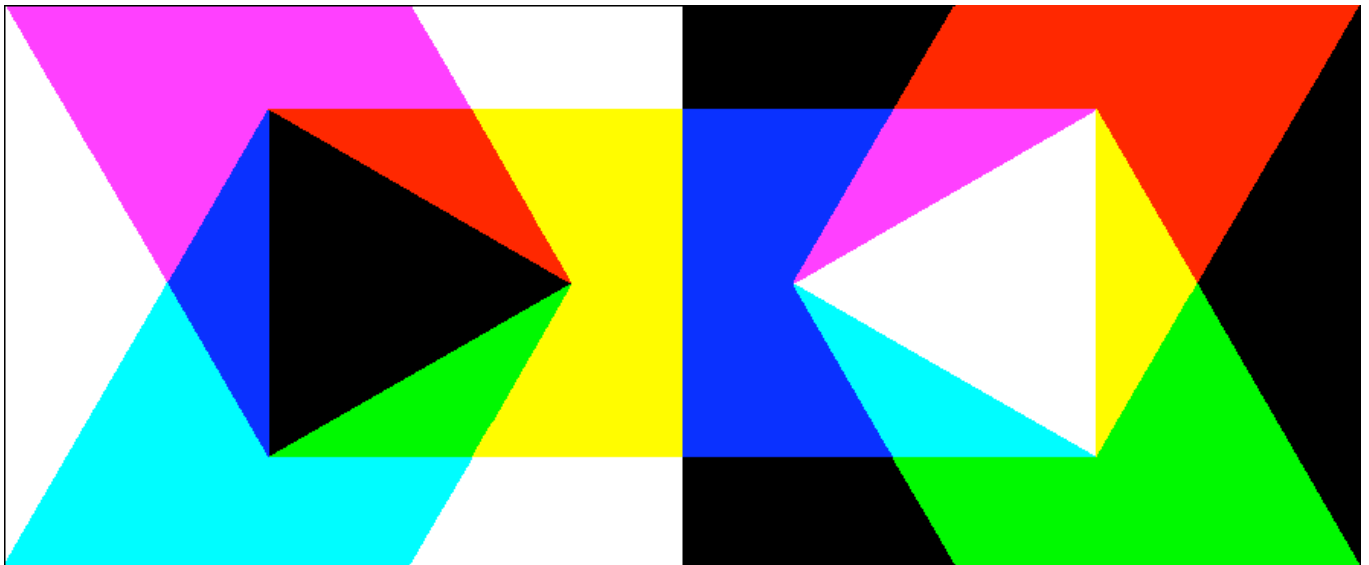

**ASSOCIATION INTERNATIONALE DE LA COULEUR
INTERNATIONALE VEREINIGUNG FÜR DIE FARBE
INTERNATIONAL COLOUR ASSOCIATION**

**NEWSLETTER
2008**



NO. 21

EDITED BY
Roy S. Berns
Munsell Color Science Laboratory
Chester F. Carlson Center for Imaging Science
Rochester Institute of Technology
U.S.A.
berns@cis.rit.edu

TABLE OF CONTENTS

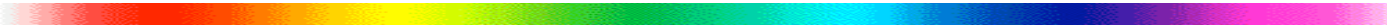

EDITOR'S CORNER.....	4
PRESIDENT'S REPORT.....	6
AIC ACCOUNTS.....	8
AUDITORS' REPORTS.....	9
EXECUTIVE COMMITTEE 2006 - 2009.....	11
REGULAR MEMBERS.....	12
INDIVIDUAL MEMBERS.....	15
JUDD AWARD.....	16
IN MEMORIAM.....	18
AIC 2006 JOHANNESBURG, SOUTH AFRICA.....	19
AIC 2007 HANGZHOU, CHINA.....	20
AIC 2008 STOCKHOLM, SWEDEN.....	21
AIC 2009 SYDNEY, AUSTRALIA.....	22
AIC 2010 MAR DEL PLATA, ARGENTINA.....	23
AIC 2011 ZURICH, SWITZERLAND.....	24
ARGENTINA.....	25
BULGARIA, REPUBLIC OF.....	26
GREAT BRITAIN.....	27
HUNGARY.....	30
ITALY.....	31
JAPAN.....	33
MEXICO.....	34
PORTUGAL.....	35
SLOVENIA.....	38
SPAIN.....	39
SWEDEN.....	41
SWITZERLAND.....	42
UNITED STATES OF AMERICA.....	44
REPORT FROM THE AIC STUDY GROUP ON COLOUR EDUCATION.....	45
REPORT FROM THE AIC STUDY GROUP ON ENVIRONMENTAL COLOUR DESIGN.....	46
REPORT FROM THE AIC STUDY GROUP ON VISUAL ILLUSIONS AND EFFECTS.....	48
REPORT FROM THE AIC STUDY GROUP ON COLOUR PERCEPTION OF THE ELDERLY.....	49
REPORT FROM CIE DIVISION 1.....	50
REPORT FROM CIE DIVISION 2.....	52

EDITOR'S CORNER

During AIC2006, I made a motion to have the Newsletter cover a calendar year period. The motion was carried and this Newsletter covers the end of 2006 and all of 2007. In the last Newsletter, No. 20, I made a request for more images from the Member Countries and our Study Groups. I showed some interesting illusions in that newsletter kindly provided by Osvaldo da Pos. To keep the ball rolling, I am enclosing some pictures taken at AIC2006 in Johannesburg and AIC2007 in Hangzhou by either Jose Luis Caivano or myself.



Following AIC2006 several of the delegates went on a guided tour to see the "Big Five." Here is my best shot.



All you can eat, South Africa style: ham on a stick. I'm wondering if the other meats I ate are endangered in other parts of the world.



My first experience with green tea that is still growing during a hiking excursion above the city of Hangzhou.



A "light" lunch I ordered with one of my students without a common language.



One of many banquets I experienced in Hangzhou.



Handing off the AIC flag from Professor Ye, Conference Chair of AIC2007, to Ms. Bergstrom, Conference Chair of AIC2008.

This newsletter can be downloaded at:
<http://www.aic-color.org/> or <http://www.aic-colour.org/>.

Roy S. Berns
April 2008

PRESIDENT'S REPORT



Dear friends, since my previous words in Newsletter 20, plenty of things have happened that I consider worth reporting.

The Interim Meeting on “Colour in Fashion and Colour in Culture” was held in Johannesburg in October 2006, organized by the Colour Group of South Africa, headed by Natasha van Tonder. Sixty-four participants from 14 countries contributed 36 presentations, divided into 26 oral papers and 10 posters. Then, in July 2007, the Midterm Meeting, “Color Science for Industry,” was organized by the Color Association of China in Hangzhou under the leadership of Guanrong Ye. There were more than 120 participants from 20 countries and 88 papers were presented: four invited lectures, 51 oral papers and 32 posters. This AIC meeting was coordinated with the 26th Session of the CIE, held in Beijing the week before. The proceedings from both the 2006 and 2007 AIC meetings have been published in paper and in CD-ROM. These proceedings are available in printed copy from the organizers and in PDF format at the AIC website. Photo galleries of the 2006 and 2007 meetings were also uploaded on the Internet.

During the Midterm Meeting 2007 there were other accomplishments as well: the Judd Award was bestowed to Alan R. Robertson, the AIC executive committee approved the interim and midterm meetings for 2010 and 2011, and a series of modifications to the AIC statutes were voted and approved at the general assembly.

As it happens every two years since 1975, the Judd Award – the highest distinction of the AIC for researchers who made lifetime contributions to color science – was presented in 2007. In this opportunity Alan R. Robertson (Canada) received the award in recognition to his influential research on color measurement and evaluation of color differences, for his contributions to a wide variety of other fields of color science and metrology, for example, studies on color order systems aimed at solving conceptual differences between the Munsell system and the NCS, as well as for his commitment to disseminate this knowledge. The Judd Award was partially sponsored by the Colour Society of Australia and the AIC also recognizes the contributions made by the NCS (Natural Color System) and the Color Association of China.

The AIC executive committee approved the proposals for the Interim Meeting 2010 in Mar del Plata, Argentina, on the theme “Color and Food: From Production to Consumption”, and for the Midterm Meeting 2011 in Zurich, Switzerland, on the theme “Staging Colour.” The details of both meetings were developed at the general assembly, in addition to the updated presentations of the Interim Meeting 2008 in Stockholm, Sweden, and the 11th Congress 2009 in Sydney, Australia. Suggestions for meetings for 2012 and 2013 were received from Japan and Great Britain, and together with the national associations of these countries, the AIC executive committee is working to delineate and be able to approve these proposals.

At the general assembly 2007, the modification of the AIC statutes was approved by vote of the regular members. Of the 25 AIC regular members at that moment, a majority of 17 members voted in favor; there were not any votes against or abstentions. (Eight regular members were not present at the assembly and did not send their vote.) The new statutes are based on the ones approved in Winterthur, Switzerland in 1988, modified and updated by the AIC executive committees of the 2002-2005 and 2006-2009 terms. The main changes approved were:

- The category of “observer” is replaced by “individual member,” allowing persons domiciled in any country (even in countries with a national color association that is an AIC regular member) to become members. The idea behind this is to have more direct contact with people.
- The general assembly is to be held every two years (at Midterm Meetings and Congresses) instead of every four years (only at Congresses).
- The membership dues are to be voted on by members rather than fixed by the statutes or established by the executive committee.
- The different guidelines that appeared at the end of the 1988 statutes have been placed in separate documents. These guidelines are approved by the AIC Executive Committee.

The new statutes and the updated guidelines are available in the AIC website.

The electronic bulletin continued to be sent by e-mail, and since December 2006 it was also posted on the web. Six bulletins were issued in 2006, while seven appeared in 2007. More than 700 e-mail addresses receive *AIC e-news*. By February 2007, all previous issues of the *AIC Newsletter*, which started in 1984, had been converted to PDF and uploaded to the web, so that a good deal of the history of the AIC is now available to anyone through these documents. In addition, with the aim of making the AIC well known worldwide, articles were written and published in the *Wikipedia* in five languages: English, Spanish, German, Portuguese and Italian (with the help of F. Rochow, M. Durao and O. da Pos). French and Swedish versions will appear soon.

Finally, it is with great sorrow that I have to recall that at the end of September 2007 we received the sad news of the decease of Prof. Tarow Indow, who was the third president of the AIC, during the 1974-1977 term, and who received the Judd award in 1989. With Tarow, we have lost a very

important personality in the history of the AIC and a most kind human being.

But on the bright side of the news, with regard to membership, I now have the opportunity to welcome two recent individual members, Ana Marija Grancaric from Croatia and Renata Pompas from Italy, and a new regular member, the Mexican Association of Color Researchers. We have also been in contact with people from other countries and I can report that efforts are being made in Chile, Colombia, Croatia and Turkey towards creating national color associations that could be incorporated into the AIC in the future.

Now, I must say: "Until the next Newsletter!" However, I will keep in contact with you through the electronic bulletin and e-mail, and I hope to see many of you personally at AIC 2008 in Sweden. Please feel free to write

to me at any time, to contribute with information and ideas, to pose questions and even criticism, with the intention of making the AIC the best forum for the exchange of knowledge about color and an excellent community where lifetime friends can be found. We want to hear from you.

A handwritten signature in black ink, appearing to read 'José Luis Caivano', with a stylized flourish at the end.

José Luis Caivano
AIC president

Compiled Data of AIC Account January 1st 2006- December 31st 2007

Opening Balance January 1st, 2006:

UBS	7.082,17	CHF
Cash	2.154,07	CHF
<hr/>		
Total	9.236,24	CHF

Incomes:

UBS	4.526,70	CHF
Cash	1.132,70	CHF
<hr/>		
Total	5.659,40	CHF

Expenditure:

UBS	5.655,58	CHF
Cash	0,00	CHF
<hr/>		
Total	5.655,58	CHF

Closing Balance December 31st, 2007:

UBS	5.953,29	CHF
Cash	3.286,77	CHF
<hr/>		
Total	9.240,06	CHF

AUDITORS' REPORTS

John Hutchings
food colour and appearance consultant

6 Queens Road
Colmworth
Bedford MK44 2LA
United Kingdom

tel +44 (0)1234 376768
john.hutchings@physics.org

Professor Javier Romero (AIC Secretary/Treasurer)
Departamento de Óptica. Facultad de Ciencias
Universidad de Granada
18071 Granada, Spain

Dear Professor Romero,

Audit Report

AIC accounts for the two years ending 31st December 2007

I have copies of the AIC accounts and bank statements relating to the period ending 31st December 2007.

I am happy to report that the UBS Bank Basel account statements agree with the records of income and expenditure for the above period. The closing balance in the UBS account at 31st December 2005 is 5,953.29 CHF. For obvious logistical reasons I am unable to confirm the cash balance of 3,286.77 CHF shown in the cash account. However, the accounts have been kept in an exemplary manner, and there is no known reason to believe this total is incorrect.

It is noted that the cash in hand now amounts to more than one third of total AIC assets. The cash requirements of the Secretary/Treasurer do not appear to be substantial, so I recommend that he consider depositing a substantial proportion of it with the bank.

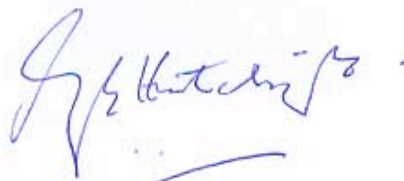

Prof. Jin Sook Lee
Chungnam National University

Prof. Javier Romero (AIC Secretary/Treasurer)
Dept. Optica. Fac. de Ciencias.
Universidad de Granada.
18071 Granada, Spain.

Division of Architecture,
College of Engineering,
Chungnam National University
220 Gung-Dong, Yuseong-Gu, Daejeon,
305-764, Republic of Korea.
Phone: +82-42-821-6573
Fax: +82-42-823-9467
e-mail: js_lee@cnu.ac.kr

26 January 2007

Audit Report

AIC 2006-01-01 – 2007-12-31

I have copies of the AIC accounts, open membership payments, bank statement and additional comments, relating to the twenty four months period ending on December 31st, 2007.

I am happy to report that the UBS Bank Basel account statements agree with the records of income and expenditure for the above period. The closing balance in the UBS account at 31st December 2007 is 5.953,29 CHF. For obvious logistical reasons I am unable to confirm the balance of 3.286,77 CHF shown in the cash account. However, the accounts have been kept in an exemplary manner there is no known reason to believe that this total is incorrect.

Your Sincerely,



Jin Sook, Lee

EXECUTIVE COMMITTEE 2006 - 2009

AIC PRESIDENT

Prof. José Luis Caivano
Universidad de Buenos Aires
Secretaría de Investigaciones FADU-UBA
Ciudad Universitaria Pab. 3 piso 4
1428 Buenos Aires
ARGENTINA
Tel: +54 11 4789 6289
Fax: +54 11 4702 6009
Email: caivano@fadu.uba.ar

AIC VICE PRESIDENT

Mrs. Berit Bergström
Swedish Colour Centre Foundation
P. O. Box 49022
S-10028 Stockholm
SWEDEN
Tel: +46 8 617 4711; +46 733 700 714
Fax: +46 8 617 4747
Email: swedish.colour.centre@nsccolour.com

AIC SECRETARY/TREASURER

Prof. Dr. Javier Romero
Dpt. de Óptica
Facultad de Ciencias
Campus Fuentenueva s/n
Universidad de Granada
E-18071 Granada
SPAIN
Tel: +34 958 244241
Fax: +34 958 248533
Email: jromero@ugr.es

AIC EC MEMBER

Prof. Dr. Roy Berns
Munsell Color Science Laboratory
Chester F. Carlson Center for Imaging Science
Rochester Institute of Technology
54 Lomb Memorial Drive
Rochester, New York 14623-5604
U.S.A.
Tel: +1 585 475 2230
Fax: +1 585 475 5988
Email: berns@cis.rit.edu

AIC EC MEMBER

Prof. Dr. Osvaldo da Pos
Department of General Psychology
University of Padua
Via Venezia 8
35131 Padova
ITALY
Tel: +39 049 827 6680
Fax: +39 049 827 6600
Email: osvaldo.dapos@unipd.it

AIC EC MEMBER

Mr. Nick Harkness
Nick Harkness Pty Ltd
Birdcage 3.1
65 Doody Street
Alexandria NSW 2015
AUSTRALIA
Tel: +61 2 9700 8110
Fax: +61 2 9700 8112
Email: nick@nhpl.com.au

AIC EC MEMBER

Prof. Dr. Guanrong Ye
Zhejiang University Hangzhou
Institute of Optical Radiation Technique (ORT)
310027 Hangzhou
PEOPLES' REPUBLIC OF CHINA
Tel: +86 571 8795 1191, 1183
Fax: +86 571 8796 8967
Email: ygr@moi-lab2.zju.edu.cn; ygr@mail.hz.zj.cn

REGULAR MEMBERS

GRUPO ARGENTINO DEL COLOR

Dr. Arch. María Luisa F. Mattiello
SICyT-FADU-UBA
Ciudad Universitaria Pab. 3 piso 4
C1428BFA Buenos Aires
ARGENTINA
Tel: +54 11 4789 6289
Email: gac@fadu.uba.ar
Website: www.fadu.uba.ar/sitios/sicyt/color/gac.htm

COLOUR SOCIETY OF AUSTRALIA

Dr. Ken Pidgeon
Dr. Ken Pidgeon Professional Partners Pty Ltd.
A.C.N. 083 213 496
4 Morning Glory Avenue
5158 O'Halloran Hill S.A.
AUSTRALIA
Tel: +61 8 8381 3192
Fax: +61 8 8381 1546
Email: kpidgeon@bigpond.com
Website: www.coloursociety.org.au/

ASOCIACIÓN BOLIVIANA DEL COLOR

Mr. Nicolás Petit
Av. José María Achá y calle 5, bloque 68, Dto.
P.O. 101 Box 10305
La Paz
BOLIVIA
Tel: +591 2 772 780 98
Fax: +591 2 2772 516
Email: asociacionbolivianadelcolor@entelnet.bo

ASSOCIAÇÃO BRASILEIRA DA COR

Mr. Hans-Peter Struck
Rua Felipe Neri 115 apto. 4
90440-150 Porto Alegre-RS
BRASIL
Tel: +55 51 331 7424
Fax: +55 51 331 7424
Email: hstruck@terra.com.br

COLOUR GROUP- BULGARIA

Mr. Krassimir Krastev
Central Post Office
P. O. Box 744
BG- 1000 Sofia
REPUBLIC OF BULGARIA
Tel: +359 88 977 908
Email: color_bg@hotmail.com

COLOR ASSOCIATION OF CHINA

Prof. Guanrong Ye
Zhejiang University Hangzhou
Institute of Optical Radiation Technique (ORT)
310027 Hangzhou
PEOPLES' REPUBLIC OF CHINA
Tel: +86 571 8795 1191, 1183
Fax: +86 571 8796 8967
Email: ygr@moi-lab2.zju.edu.cn, yg@mail.hz.zj.cn

SUOMEN VÄRIYHDISTYS SVY RY

Ass. Prof. Harald Arnkil
Kangastie 9
FIN 00630 Helsinki
FINLAND
Tel: +358 9 798 117
Fax: +358 9 756 30577
Email: harnkil@uia.fi
Website: www.svy.fi

CENTRE FRANÇAIS DE LA COULEUR

Prof. Dr. Patrick Callet
41, rue Pajol
75018 Paris
FRANCE
Tel: +33 (0) 1 74 308036
Email: vice-president@cf-couleur.fr
Website: www.cf-couleur.fr

DEUTSCHER VERBAND FARBE

Dipl.-Ing. Frank Rochow
LMT Lichtmesstechnik GmbH Berlin
Helmholtzstrasse 9
D-10587 Berlin
GERMANY
Tel: +49 30 393 4028
Fax: +49 30 391 8001
Email: offices@rochow-berlin.de
Website: www.deutsches-farbenzentrum.de

THE COLOUR GROUP (GREAT BRITAIN)

Mr Roy Osborne
17 Hepplestone Close
London
SW15 5DE
GREAT BRITAIN
Email: art.school@virgin.net
Website: www.city.ac.uk/colourgroup

HUNGARIAN NATIONAL COLOUR COMMITTEE

Prof. Antal Nemcsics
Ungvár u. 42
H-1185 Budapest
HUNGARY
Email: nemcsics.antal@axelro.hu

ASSOCIAZIONE OTTICA ITALIANA

Prof. Lucia R. Ronchi
1, via Sour Maria Celeste
I-50125 Firenze
ITALY
Tel: +39 55 22 2112
Fax: +39 55 22 2090
Email: lucia.ronchirositani@associazioneotticaitaliana.info
Website: www.associazioneotticaitaliana.info

COLOR SCIENCE ASSOCIATION OF JAPAN

Dr. Yoshitsugu Manabe
 Graduate School of Information Science
 Nara Institute of Science and Technology
 8916-5 Takayama, Ikoma
 630-0192 Nara
 JAPAN
 Tel: +81 743 72 5271
 Fax: +81 743 72 5279
 Email: manabe@is.naist.jp
 Website: www.soc.nii.ac.jp/color

KOREAN SOCIETY OF COLOR STUDIES

Prof. Kyung-Don Rhee
 PoongLim Iwant C-1616
 Seohyun-Dong, Boondang, Sungnam-Si
 Kyungki-Do
 REPUBLIC OF KOREA
 Email: chair@color.or.kr
 Website: www.color.or.kr

ASOCIACIÓN MEXICANA DE INVESTIGADORES DEL COLOR

Dra. Georgina Ortiz
 Calle B #22, Mz. 10, Col. Educación
 CP 04400, Delegación Coyoacan, México, DF
 MEXICO
 Tel: +55 1 5622 2264
 Fax: +55 1 5622 2256
 E-mail: geortiz@servidor.unam.mx
 Website: http://www.amexinc.org.mx

NEDERLANDSE VERENIGING VOOR KLEURENSTUDIE

Mrs. Erna Tielen
 Ottoweg 7
 NL-6866 CE Heelsum
 THE NETHERLANDS
 Tel: +31 317 311 977
 Fax: +31 317 311 550
 Email: info@kleurenvisie.nl
 Website: www.kleurenvisie.nl/

NORSK FARVEFORUM

Mr. Harald Anthonsen
 National College of Art and Design
 Institute of Colour
 Ullvalsn 5
 N-0165 Oslo
 NORWAY
 Tel: +47 2299 5680 (direct 5616)
 Fax: +47 2299 5585

GLÓNY URZAD MIAR

Mr. Lukasz Litwink
 Optical Radiation Standards Laboratory
 Ul. Elekoralna 2
 PL-00-950 Warszawa P-10
 POLAND
 Tel: +48 22 620 4029, +48 22 620 0241 ext. 9549
 Fax: +48 22 620 5435
 Email: vprbl@gum.gov.pl
 Website: www.gum.gov.pl/pl/site

ASSOCIAÇÃO PORTUGUESA DA COR

Dr. Maria Joao Durao
 Faculdade de Arquitectura da UTL
 Rua Prof. Cid dos Santos
 Polo Universitário- Alto da Ajunta
 P-1349-055 Lisboa
 PORTUGAL
 Tel: +351 213 615 000
 Fax: +351 213 625 138
 Email: mjdurao@fa.utl.pt

DRUSTVO KOLORISTOV SLOVENIJE

Prof. Dr. Slava Jeler (President)
 Dunja Legat (Secretary)
 Ventrinjska 16
 SI-2000 Maribor
 SLOVENIA
 Tel: +386 (0) 2 429 5322, +386 (0) 250 1323
 Fax: +386 (0) 2 250 1324
 Email: legat@uni-mb.si
 Website: www.dks-drustvo.si

COLOUR GROUP OF SOUTH AFRICA

Mrs. Natasha van Tonder
 National Metrology Laboratory CSIR
 Room 194, Building 5
 P. O. Box 395
 Pretoria 0001
 REPUBLIC OF SOUTH AFRICA
 Tel: +27 12 841 3618
 Fax: +27 12 841 2131
 Email: nvtonder@csir.co.za
 Website: www.colourgroupsa.org.za

COMITÉ ESPAÑOL DEL COLOR

Dr. Manuel Melgosa
 Departamento de Óptica
 Facultad de Ciencias
 Universidad de Granada
 18071 Granada
 SPAIN
 Tel: +34 958 246364
 Fax: +34 958 248533
 Email: mmelgosa@ugr.es
 Website: http://sedo.optica.csic.es/color/color.html

STIFTELSEN SVENSKT FÄRGCENTRUM

Mrs. Berit Bergström
 Swedish Colour Centre Foundation
 Igeldammsgatan 30
 P. O. Box 49022
 S-100 28 Stockholm
 SWEDEN
 Tel: +46 8 617 4711, +46 733 700 714
 Fax: +46 8 617 4747
 Email: swedish.colour.centre@nescolour.com
 Website: www.nescolour.com

PRO COLORE

Schweizerische Vereinigung fuer die Farbe
Eveline Staub (Executive Director)
Postfach 8701
CH-8036 Zurich
SWITZERLAND
Tel. +41 44 342 36 08
Fax +41 44 342 36 09
Email: info@procolore.ch
Website: <http://www.procolore.ch/>
<http://www.procolore.ch/vorstand.html>

THE COLOR GROUP OF THAILAND

Prof. Dr. Aran Hansuebsai
Department of Imaging and Printing Technology
Faculty of Science
Chulalongkorn University
Phyathai Rd.
Bangkok 10330
THAILAND
Tel: +66 2 218 5588/9, +66 2 218 5581/2
Fax: +66 2 254 6530, +66 2 255 3021
Email: aran@sc.chula.ac.th

INTER-SOCIETY COLOR COUNCIL

Mrs. Cynthia J. Sturke
C/o Hunter Associates Laboratory Inc
11491 Sunset Hills Road
Reston, VA 20190
UNITED STATES OF AMERICA
Tel: +1 703 318 0263
Fax: +1 703 318 0514
Email: iscc@coompuserve.com, cstaurke@aol.com
Website: <http://www.iscc.org>

INDIVIDUAL MEMBERS

Dr. Leonhard Oberascher

Kaltnergasse 8
A-5020 Salzburg
AUSTRIA
ecd@leoncolor.com

Dr. Alan R. Robertson

Photometry & Radiometry Group
Institute for National Measurement Standards
National Research Council of Canada
1200 Montreal Road, M-36, Room 1141
Ottawa, ON, K1A 0R6
CANADA
Tel: 613 993-9347 / Fax: 613 952-1394
alan.robertson@nrc.ca

Prof. Dr. Ana Marija Grancaric

University of Zagreb, Faculty of Textile Technology
Prilaz baruna Filipovica 30, HR-10000 Zagreb
CROATIA
Tel.: +385 1 48 77 360
Fax: +385 1 48 77 355
amgranca@ttf.hr

Mrs. Mette Terkildsen

Dansk Farveinstitutet
Lillevangspark 30
DK-3520 Farum
DENMARK
Tel: +45 70209978
info@danskfarveinstitut.dk

Prof. Dr. Theano F. Tosca

Aristotle University of Thessaloniki
Dept. of Architectural Design & Visual Arts
Priv. 17, Athan Soulioti Street
546 42 Thessaloniki
GREECE
tosca@eng.auth.gr

Ms. Latika Khosla

Freedom Tree Design
Siverene
63 Worli Sea Face Road
Worli
400018 Mumbai
INDIA
latika@hathway.com

Dr. Renata Pompas

Corso Ventidue Marzo, 4
20135 Milano
ITALIA
Tel/Fax: +39 2 5519 2384
renata.pompas@libero.it

Dr. Andrew Chalmers

Dept. of Electronics & Computer Engineering
Manukau Institute of Technology
Newbury Street 09
Private Bag 94006
Manukau City, Auckland
NEW ZEALAND
chalmers@manukau.ac.nz

Dr. Diplo.-Ing. Andrea Urand

Spitalska c. 59
811 08 Bratislava
SLOVAK REPUBLIC
a_urand@yahoo.com

Dr. Susan Habib

6. Sokak 43
Bahcelievler 06500
Ankara
TURKEY
lapismapple@gmail.com

Dr. Nilgün Camgöz-Olgunturk

Bilkent University
Faculty of Art, Design and Architecture
Dept. of Interior Architecture and Environmental Design
Oyak 10 Sitesi
16/20 Koru Mah Gayyolu
06810 Ankara
TURKEY
onilgun@bilkent.edu.tr

Assoc. Prof. Rengin Ünver

Yildiz Technical University
Faculty of Architecture
Building Physics Dept.
Besiktas
80750 Istanbul
TURKEY
runver@yildiz.edu.tr

JUDD AWARD

ALAN R. ROBERTSON



Judd Medal.

The AIC Deane B. Judd Award was established in 1973 to honor the memory of Deane B. Judd; it is the highest honor that can be bestowed by the international color community. The Award recognizes work of international importance in the fields of color perception, color measurement, and/or color technology. The Award is presented every two years, at AIC Congresses and Mid-term meetings. The 2007 recipient was Dr. Alan R. Robertson. He was honored at the 2007 Mid-term meeting in Hangzhou, China.



Alan R. Robertson

The following paragraphs were written by the Colour Group (GB).

“Alan R. Robertson was educated at King Edward’s School, Birmingham, England. He received his B.Sc. in 1962 and his Ph.D. in 1965, both from Imperial College of the University of London, England. His Ph.D. was under the supervision of Professor W. David Wright and resulted in a thesis entitled “Errors in spectrophotometry with particular reference to near-white and near-black surfaces.” After leaving Imperial College, he went to the National Research Council of Canada (NRC) to work as a Post-Doctoral Fellow under Dr. Günter Wyszecki. He joined the continuing staff of NRC in 1966 and by 1984 had risen to the position of Senior Research Officer and Group Leader of the Photometry and Radiometry Group. He retired from NRC in 2000 after serving as Director of the Chemical and Mechanical Standards Section and Strategic Advisor to the Director General of the Institute for National Measurement Standards. In retirement, he has continued to work part-time at NRC as a Visiting Worker.

One of his first projects at NRC was the development of digital methods for calculating correlated colour temperature and distribution temperature. The method for correlated colour temperature has been used by many lamp manufacturers and spectroradiometer manufacturers who built it into their computer programs and for many years it was the de facto standard method for these calculations, superseded only recently by more modern optimization techniques.

His Ph.D. thesis led to a paper on the propagation of uncertainties in colour measurement that was ahead of its time and has formed the basis of several recent papers on the subject responding to the current interest in determining and specifying the uncertainties of measurement. His interest and expertise in spectrophotometry continued at NRC and he developed NRC’s spectrophotometric facilities to a position of world leadership. He performed pioneering work on the characterization and use of stable working standards for reflection spectrophotometry and, in 1987, published a seminal paper on the use of diagnostic standards to improve the performance of spectrophotometers. This work forms the basis for the modern technique of “profiling” which is used by spectrophotometer and colorimeter manufacturers to improve the performance of their instruments in the field.

During the late 1960s and early 1970s, Dr. Robertson participated in a major experimental program at NRC to measure new colour-matching ellipses. This led to a life-long interest in colour-difference evaluation. He has been a leader in the development of color difference formulae and played an active role in the establishment of the 1976 CIELAB and CIELUV color difference formulae, chairing the working group that did the final development of the formulae and fixed the constants. From 1976 to 1987, he chaired an international committee organizing collaborative research aimed at developing new standard colour-difference formulae to improve on the 1976 formulae. He remained as an advisor to subsequent committees and played a role in the development of the CIE94 and CIEDE2000 formulae.

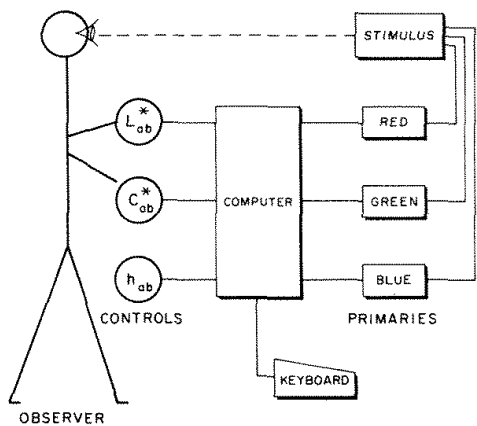

Dr. Robertson anticipating the use of computer-controlled displays for color experiments, "The Future of Color Science", Col. Res. Appl. 7(1), 16-18 (1982).

His contributions to colour science have not been limited to spectrophotometry and colour-difference evaluation. He studied colour order systems, writing several papers on the subject and playing a prominent role in CIE and ISO committees that attempted to resolve differences in philosophy between the Munsell and NCS systems. He has served as a consultant to CIE committees that developed chromatic adaptation transforms and color appearance spaces. His 1983 paper on metamerism was instrumental in resolving misunderstandings concerning the definition of metamerism that were prevalent at that time.

In retirement, he is pursuing another area of interest – that of the validity of Grassmann's Laws of colour matching. Spurred by his experience in making colour matches on the Wright Colorimeter and the NRC Trichromator and by William Thornton's results and his controversial explanations of them, Alan has been working with students at the University of Leeds to study the uncertainty and additivity of colour matching.

Throughout his career, Alan has demonstrated excellent leadership. He was head of the Photometry and Radiometry Group and the Chemical and Mechanical Standards Section of NRC. He has been a leader within the CIE and the AIC, serving as Associate Director of CIE Division 1 from 1989 to 1991, as CIE Vice President from 1995 to 1999, and as AIC President from 1990 to 1993. He is the longest-serving member of the Canadian National Committee of the CIE, having served continuously as a member since 1967 and as President from 1985 to 1992. He has been a Director of the Inter-Society Color Council and President of the Canadian Society for Color. He has also served in a broader capacity in the field of metrology, particularly in the North American Cooperation in Metrology (NORAMET), and the Inter-American Metrology System (SIM). He had a key role and influence in the drafting and implementation of an historic document (the CIPM MRA), signed in Paris in 1999 by the Directors of 38 National Measurement Institutes.

Alan has always been actively involved in standardizing color. He has a commitment to teaching the world how to do color science the correct way and that is why the push for standards that would be available to organizations outside the CIE has been so important to him. He played a role in the establishment of the first CIE standards, S001 on Standard Illuminants for Colorimetry, and S002 on Standard Colorimetric Observers. In the late 1990s, aware of the

diversity of colour standards in the field of imaging and of the need for the CIE to take on a leadership role, he formed and chaired an ad hoc working group that was responsible for the creation of CIE Division 8 on Image Technology to look into the optical, visual and metrological aspects of the communication, processing and reproduction of images. This initiative was widely praised in the community. Alan is currently the chair of CIE TC1-57 on Standards for Colorimetry and of TC2-57 on standard illuminants.

He is the author of over 60 published papers, many of them still widely quoted, and is the author or co-author of one book and three book chapters. In 1992 he was honoured to be invited to write an article on colour perception for a special issue of *Physics Today*. He is an excellent speaker and has given numerous invited talks throughout the world.

In 2005, the ISCC honoured Dr. Robertson with the presentation of its Godlove Award. Founded in 1931, the ISCC is an organization of societies and creative individuals that work to propagate the understanding of color in art, science and industry. The Godlove Award was named for Dr. I. H. Godlove and is the highest honour bestowed by the ISCC. It is given in recognition of a lifetime of distinguished service to the color community. Dr. Robertson received the Canadian Society for Color Merit Award in 1981 and is an Honorary Member of the Grupo Argentino del Color. He was also privileged to be the Grum Memorial Speaker of the Council for Optical Radiation Measurements in 1991."



Dr. Robertson giving the Judd Lecture.

IN MEMORIUM

PROFESSOR TAROW INDOW



The AIC was saddened to receive the notice of the death of Tarow Indow, who passed away on September 22, 2007. He was president of the International Color Association from 1974 to 1977, and received the AIC Judd Award in 1989, during the 6th AIC congress.

At the time of his death, he was a Professor Emeritus at both Keio University and the University of California, Irvine.

He was born in Tokyo on August 22, 1923. The first part of his education and career centered at Keio University in

Tokyo where he received a Ph.D. in 1945 and rose to a full professorship. He married Minako Kawamura, a private high school language teacher, in 1953, and she survives him.

He held visiting positions at Harvard, the Institute for Advanced Study, and UC Irvine where he became a professor in cognitive sciences in 1979. He was one of the founding members of the Institute for Mathematical Behavioral Sciences at UC Irvine, and a frequent presenter as well as faithful attendee of Institute colloquia. A festschrift was held in 1993 in his honor on his 70th birthday. In that year, he retired but continued research activities on developing color measures in collaboration with professor emeritus A. K. Romney.

Indow is best known for his clever, unambiguous empirical demonstration that our visual space is not the Euclidean geometry of high school, as seems intuitively obvious, but rather of a curved nature. His research, reported in over 100 technical papers in major journals, covered, in addition to geometric representations of visual space, formalisms of color space and of stochastic representations of semantic memory, and ability testing.

In addition to the Judd Award, he received awards from Keio University (1961), the Japanese Association of Illuminating Engineering (1973), and his election in 1986 to be a fellow of the honorary Society of Experimental Psychologists.

His research on the multi-dimensional scaling of the Munsell System and defining discrimination confidence ellipsoids (with M. L. Morrison) are widely referenced in color science.

AIC 2006 JOHANNESBURG, SOUTH AFRICA



During October 24 – 27, 2006, the Colour Group of South Africa hosted the AIC 2006 Interim Meeting, Colour in Culture and Colour in Fashion. It was held at the Misty Hills Country Hotel, a rustic retreat just outside of Johannesburg.

The proceedings can be downloaded from the AIC website: <http://www.aic-color.org/>.

Pictures from the conference can be viewed at: http://www.colourgroupsa.org.za/aic2006/aic_information.php.



Ms. Natasha van Tonder, Conference Chair, welcoming attendees.



Registering at the conference.

AIC 2007 HANGZHOU, CHINA



The AIC Midterm Meeting was held July 12-14 2007 in Hangzhou, China. The theme was “Color Science for Industry” and was organized by the Color Association of China.

The proceedings can be downloaded from the AIC website: <http://www.aic-color.org/>. The conference website was: <http://www.aic07.com/>.



Professor Ye, Conference Chair, opening the conference.



Beautiful Lake Hangzhou



Opening ceremony.

AIC 2008 STOCKHOLM, SWEDEN



An AIC Interim Meeting will be held June 15-18 2008 in Stockholm, Sweden at Hotel Rival, a boutique hotel located in the heart of Stockholm. The hotel is shaped by the vision of its owner, Benny Andersson – a known songwriter and performer from the ABBA group. The conference will cover a wide range of topics related to the theme “Colour – Effects and Affects.” Different aspects of the effect of using colour in interior and exterior design like change of colour impressions depending on distance, light sources, colour combinations and interaction of colours etc. Different aspects of how colours affect us like colour psychology, colour meaning, colour associations and colour emotions.

CONFERENCE TOPICS:

- Colour in interiors
- Colour in architecture
- Colour in landscape and urban space
- Colour design for people with special needs
- Colour in product and textile design
- Colouring in graphic & computer design
- Light and colour
- Colour appearance and visual illusions
- Colour symbolism and associations
- Psychological and biological effects of colours
- Colour harmony and aesthetics
- Colour in art and in culture
- Colour and education
- Colour measurement and specification

The meeting will start June 15th with registration and poster hanging from 3:00 pm until 6:30 pm. The welcoming reception will start at 7:00 pm at the NCS – Scandinavian Colour Institute AB. On June 16th – 18th there will be a full conference program. On Monday evening a reception in the Stockholm City Hall will be held at 6:00 pm and on Tuesday evening a Banquet Dinner will take place at Restaurant Höglöftet at Skansen. Skansen is a famous open-air museum located on the island of Djurgården, a royal park near the center of Stockholm.

The Meeting is being organized by the Swedish Colour Centre Foundation.



Conference venue, Hotel Rival

FOR MORE INFORMATION

Mrs. Berit Bergström
Swedish Colour Centre Foundation
P. O. Box 49022
S-10028 Stockholm, SWEDEN
Tel: +46 8 617 4711; +46 733 700 714
Fax: +46 8 617 4747
Email: swedish.colour.centre@ncscolor.com
Website: <http://www.fargcentrum.se>

AIC 2009 SYDNEY, AUSTRALIA



The 11th AIC Congress will be held September 27 – October 2 2009, in Sydney, Australia, organized by the Colour Society of Australia. The venue will be the Scientia Campus Conferencing Centre at the University of New South Wales: www.conferencing.unsw.edu.au.

The technical program will be divided into the following topics:

- A. Colour in nature,
- B. Colour physics – light sources, optics,
- C. Colour chemistry – colorants, dyestuffs and pigments,
- D. Colour vision – physiology, neurology,
- E. Colour measurement,
- F. Applications of colour science – food, medicine, forensics,
- G. Colour imaging – reproduction, management, vision models,
- H. Colour psychology – perception, emotion,
- I. Colour communication – meanings, semiotics, language,
- J. Colour theory – history, philosophy,
- K. Colour in art, design and the built environment,
- L. Colour in textiles, fashion and cosmetics,
- M. Appearance measurement – surface quality, texture, gloss,
- N. Colour education.

FOR MORE INFORMATION

Mr. Nick Harkness
Nick Harkness Pty Ltd
Birdcage 3.1
65 Doody Street
Alexandria NSW 2015
Australia
Tel: +61 2 9700 8110
Fax: +61 2 9700 8112
Email: nick@nhpl.com.au
Website: <http://www.aic2009.org>



Conference venue.

AIC 2010 MAR DEL PLATA, ARGENTINA



The Executive Committee of the Argentine Color Group (GAC, Grupo Argentino del Color) would like to invite you to the AIC Interim Meeting 2010, to be held in Mar del Plata, Argentina. The conference will be held in spring (Southern Hemisphere), September or October.

LOCATION

Mar del Plata is a beautiful city at the shore of the Atlantic Ocean, in the province of Buenos Aires, 400 kilometers away from Buenos Aires. Being a tourist destination, it has extensive lodging facilities for all budgets, a great variety of theatres, a casino, and other attractions. Mar del Plata has a large harbor and important fisheries industries administrated mainly by an old Italian community that has settled in the area for over a century. Near Mar del Plata there is also a picturesque landscape of hills and small mountains.



Mar Del Plata

www.n8w.com/newweb/photos-mardelplata.php

THEME

Taking into account that the province of Buenos Aires is the largest producer of food in Argentina, and that the theme of color in food was not addressed in any previous AIC meeting, the theme proposed for this interim meeting is **Color and Food: From Production to Consumption**, comprising a variety of topics ranging from technology to design. Examples include colorimetry, color instrumentation and color technology applied in the food industry, color chemistry of food products, color physics, color and appearance in food, lighting for the exhibition or consumption of food products, color design and packaging for food products, color in commercial architecture,

restaurants, food markets, etc., advertisement and color communication of food products, color psychology, consumer expectations and color preferences related to food.

As an antecedent on this specific subject, the Argentine Color Group has the experience of having organized two national symposia about color in food, in 1982 and 1984. In order to promote the AIC meeting within the country, regional meetings on color and food have been held since 2007 and are planned in the future at different cities and provinces.

RELATED MEETING

An invitation has been made to the CIE to hold a Symposium on Measurement of Visual Appearance in Buenos Aires in 2010, the week previous to the AIC Interim Meeting in Mar del Plata.

FOR MORE INFORMATION

Dr. María Luisa F. de Mattiello
President, Argentine Color Group
gac@fadu.uba.ar

AIC 2011 ZURICH, SWITZERLAND



Ulrich Bachmann, Sabine Süssstrunk and Verena M. Schindler have launched a proposal to organize an AIC Midterm Meeting in Zurich, Switzerland. Verena M. Schindler, official delegate and member of pro/colore, presented the proposal on Thursday, July 12th, 2007, under Agenda Point 11 "AIC Meetings after 2009 (Update of Proposals for 2010 and 2011)" at the AIC Executive Committee Meeting, held during the AIC 2007 Midterm Meeting in Hangzhou, China. The main issues of the proposal presentation were the following: (1) Presentation of the pro/colore Board; (2) membership increase of pro/colore; (3) activities of pro/colore; (4) members of the AIC Colour 2011 Organizing Committee; and, AIC Colour 2011 Details, i.e., (5) theme; (6) venue; (7) date; (8) geographical location of city; (9) access, local & international transportation; (10) culture & tourism; (11) city's colour attractions; and (12) colour-specific tours.

The proposal was approved unanimously by the members of the AIC Executive Committee. Thereby in the AIC General Assembly, the pro/colore official delegate Verena M. Schindler presented the approved proposal under Agenda Point 3 "Future AIC Meetings."

The AIC Executive Committee recommended that some issues be re-considered by the AIC Colour 2011 Midterm Meeting Organizing Committee.

On December 5th, 2007, all the actual members of the AIC Colour 2011 Midterm Meeting Organizing Committee met in Zurich. The members include:

Ernesto Bergantini pro/colore President, Textile Designer, Head of the Colour Design Course and Professor at the Swiss Textile College in Wattwil and Zurich, St. Gallen;

Eveline Staub pro/colore Head Office, Colour Designer and Event Manager for a major Swiss life insurance company, Zurich;

Daniel Pfeffer pro/colore Member of Executive Committee, Head Marketing Services of Swiss Research Centre for Rationalization in Building and Civil Engineering (CRB), Representative of the NCS Colour Centre Switzerland, Zurich;

Ulrich Bachmann Researcher, Artist, Author, Professor at Zurich University of the Arts, Zurich;

Linda Cassens Stoian M.A. Artist, Theorist and Researcher with focus upon performative concepts of space, Freelance Writer, Editor and Translator, Basel;

Verena M. Schindler MSc. Art and Architectural Historian, Atelier Cler Etudes Chromatiques in Paris, France, Editor in Europe of World Architecture Magazine Publications (WA) in Beijing, China, Chair of AIC Study Group on Environmental Colour Design (ECD), Zollikon;

Sabine Süssstrunk Professor, Head of the Images and Visual Representation Group in the Audiovisual Communications Laboratory (LCAV), School of Information and Communication Sciences (I&C) at Ecole Polytechnique Fédérale de Lausanne (EPFL), Chair of CIE Division 8, Lausanne.

The following main issues were considered:

Event Title

It was decided to change the title of the AIC Colour 2011 Midterm Meeting to:

**STAGING COLOUR
FARBE INSZENIERT
LA COULEUR SE MET EN SCÈNE**

Venue

The venue will be the Zurich University of the Arts (*Zürcher Hochschule der Künste, ZHdK*).

Date

In conjunction with the CIE-Meeting that will take place in Johannesburg on July 4-14, 2011, the venue was initially scheduled for late June. However, to accommodate the schedule of the ZHdK the date will have to be in late May or early June.

For more information:

Verena M. SCHINDLER
pro/colore Official Delegate of AIC
vmschindler@yahoo.com
ecd.studygroup@yahoo.com

Postal Address:

Postfach 504
CH-8702 Zollikon
Switzerland
Tel. +41 44 391 62 74
or

Atelier Cler
64 rue Vergniaud
75013 Paris
France
Tel. +33 1 45 80 91 15

ARGENTINA

THE ARGENTINE COLOR GROUP

HISTORY

The Argentine Color Group (Grupo Argentino Color, GAC) was founded in 1980, and brings together institutions and individuals who share an interest in the study of color science and color applications. The goals of the Group are to encourage research on problems related to color, to promote the exchange of information with similar associations abroad, to manage a documentation center, and to integrate the different fields from which the study of color can be addressed: science, technology, design and education. There is also strong interest in the Group from the artistic community in the diffusion of their works. For further information, please visit our website:
www.fadu.uba.ar/sicyt/color/gac.htm

ACTIVITIES

During 2007 the objective of the Argentine Color Group was to disseminate its activities in the provinces of Argentina. Our territory is of course very large and our members are found in various important cities, but far from the capital of the Republic where our headquarters are located. We therefore decided that it should be the steering committee of the GAC that should travel.

Our first activity took place in Luján, Buenos Aires province. It took the form of an interesting exhibition in the Provincial Fine Arts Museum by 22 artists who are members of the GAC. It was truly a party of color that revealed the great enthusiasm and camaraderie of our members. The second activity took place in the Faculty of Architecture and Design at the National University of North-East in the city of

Resistencia, Chaco, with an audience that fluctuated between 300 and 350 people. It lasted two days and a total of 40 papers were presented. The third meeting took place in the Faculty of Engineering at the National Technological University in the city of Córdoba. Again, it lasted two days and was dedicated to color in industry. Altogether 30 papers were presented and six local industries attended, focusing on the question of colored concrete, colorants and paints. Lastly, the third meeting was held in Mar del Plata on the theme "Color in Food." It was of great significance for GAC, particularly since the AIC had agreed to hold its Interim Meeting 2010 in Argentina. The GAC steering committee thought that the meeting would be a good starting point for preparations for this important future event. The success obtained proved us right. It should be pointed out that this subject is particularly important for the interests of the country, which is a large exporter of food to the world.

Other activities were the monthly meetings of the steering committee, the printing of three new GAC newsletters and the organization of the biannual congress of the GAC to be held in the city of Santa Fe in September-October 2008.

CONTACT INFORMATION

Grupo Argentino del Color, SICyT-FADU-UBA
President: Maria L. F. de Mattiello
Ciudad Universitaria Pab. 3 piso 4, C1428BFA Buenos Aires, Argentina
Tel. (54-11) 4789-6289. E-mail: gac@fadu.uba.ar
Internet: <http://www.fadu.uba.ar/sitios/sicyt/color/gac.htm>

BULGARIA, REPUBLIC OF

COLOR GROUP – BULGARIA (CGB)

The Color Group of Bulgaria was pursuing activities to implement its program for promoting and developing scientific knowledge in the field of color, color science and instrumental measurements.

During the period, the following scientific and practical manifestations occurred:

1. In April 2006, the National conference “Color and Daylight” was held in Sofia. Lectures from the fields of theory and practice were presented on the following topics: light and color in the environment and light and color in science and arts. The proceedings of the conference were published on CD.

2. In November 2006, the National conference, “Color and Education” was held. Its objective was to point out the role and to show the place and the importance of color science in the frames of academic education. The proceedings of the conference were published on CD.

3. In May 2007, the National practical conference “Coloristics” 2007 was held in Sofia. This conference was addressed to technologists, colorists, quality assessors, laboratory assistants, managers, etc. The proceedings of the conference were published on CD.

4. In October 2007, the National seminar, “The Role of Advertising in Business,” was held in Sofia. The seminar was organized as a part of the program of the specialized international exhibition, “Expo Print and Pack”, in parallel

to the information technology exhibition, “BAIT Expo” 2007. The seminar was held together with the quality specialists in Bulgaria. The objective of this seminar was to promote the importance of the role of advertising in business. It was orientated to educational and scientific institutions, where future professionals in the domain of advertising are trained. The proceedings of the seminar were published in a book and on CD.

5. The Color Group of Bulgaria founded a publishing group, which is the editor of the bulletin of CGB, of books and compact disks containing the proceedings of seminars and conferences, and compact disks presenting the works of the specialists who are members of the Color Group of Bulgaria.

6. Exhibitions of painters, who are members of the Color Group of Bulgaria, were held.

CONTACT INFORMATION

President: Krassimir Krastev

Secretary: Margarita Ivanova

Address for contacts:

Color Group – Bulgaria

BG – 1000 Sofia

P.O. Box 744

BULGARIA

e-mail: colorgroup@abv.bg

GREAT BRITAIN

THE COLOUR GROUP (GREAT BRITAIN)

Registered mailing address: Prof John Mellerio, The Hon. Secretary, The Colour Group (Great Britain), c/o Applied Vision Research Centre, Tait Building, City University, Northampton Square, London EC1V 0HB.

Web address: www.colour.org.uk. Email address: colourgroupgb@city.ac.uk.

Registered with Company's House no. 00707804. Registered with The Charity Commissioners no. 1047548.

COMMITTEE MEMBERSHIP

Mr Roy Osborne (Chairman, art.school@virgin.net)

Prof Lindsay MacDonald (Vice-Chairman, l.macdonald@lcc.arts.ac.uk)

Prof John Mellerio (Secretary, j.mellerio@westminster.ac.uk)

Prof Ralph Jacobson (Treasurer, ralph@copse12.freeserve.co.uk)

Dr Alison Gilchrist (Membership Secretary, a.gilchrist@leeds.ac.uk)

Mr Andrew Hanson (Newsletter Editor, andrew.hanson@npl.co.uk)

Mr Roger Bourdon (Ordinary Member, roger.bourdon@which.net)

Dr Marisa Rodriguez-Carmona (Ordinary Member, m.l.rodriguez-carmona@city.ac.uk)

Mr Bernard Staig-Graham (Ordinary Member, bernardskairouan@hotmail.com)

Prof Andrew Stockman (Ordinary Member, a.stockman@ucl.ac.uk)

Ms Angela Wright (Ordinary Member, abw@colour-affects.co.uk)

Dr Sophie Wuerger (Ordinary Member, s.m.wuerger@liverpool.ac.uk)

AWARDS

Congratulations to Dr Alan Robertson, winner of the 2007 AIC Judd Award.

On 2 March, 2007, Berit Bergström, Chairman of the Judd Award Selection Committee, notified the Colour Group Committee that the winner of the next Judd Award was its nominee: Dr Alan Robertson of Canada. The members of the 2007 Judd Award Selection Committee were Paula Alessi, John Hutchings, Tarow Indow, Daniel Lozano, Lars Sivik, Gunnar Tonnquist and Pieter Walraven. The award was presented at the AIC Midterm Meeting 2007 in Hangzhou, China, 12-14 July 2007.

Congratulations to Dr Robert Hunt, winner the 2007 ISCC Godlove Award.

On 16 February, 2007, Dr Alan Robertson of the ISCC Godlove Award Selection Committee notified the Colour Group Committee that the winner of the next Godlove Award was its nominee, Honorary Member, Newton Medallist and first Colour Group Chairman, Dr Robert William Gainer Hunt. This is the highest honour awarded by the ISCC. Its presentation ceremony was a highlight of the ISCC meeting in Kansas City (USA), 29 April-1 May, 2007.

Congratulations to Dr Peter Vukusic, selected as the Institute of Physics' 2007 Schools Lecturer. Colour Group member Peter Vukusic's research covers the optics and photonics of animals and plants, and he is a former physics teacher. His assignment is to present interactive lectures to about 10,000 school students throughout Britain. In 2004 he won the international L'Oreal Art and Science of Colour prize, and he has given numerous lectures and presentations on the science of colour to audiences of all ages around the world.

COLOUR GROUP PROGRAMME 2006

Thursday, 12 January, 2006. Annual Vision Meeting. Palmer Lecture introduced by John Mollon FRS & presented by Françoise Viénot, Museum national d'histoire naturelle, Paris ('From gloss scaling to gloss constancy'). Other presenters: by Almut Kelber, University of Lund ('Colour vision in nocturnal animals'), Peter Vukusic, University of Exeter ('Controlling the flow of colour: advanced photonic systems in Lepidoptera'), David Brainard, University of Pennsylvania ('Bayesian models of colour appearance: understanding the appearance of small spot colours'), Kenneth Knoblauch, INSERM, Lyons ('The neural substrate of transparency perception'), Marina Bloj, University of Bradford ('Seeing non-uniform colours'), Annette Werner, University of Tübingen ('Colour constancy in motion'), Beau Lotto, Institute of Ophthalmology ('The role of noise in resolving lightness constancy in bumblebees'). Venue: Institute of Ophthalmology, London. Organiser: Daniel Osorio.

Wednesday, 1 February, 2006. 'Colour Symbolism'. Presenter: Roy Osborne, Florida State University, London ('Colour symbolism: from antiquity to the present day' & 'Colour in fashion and dress, 1500 to the present day'). Venue: City University, London. Organiser: Roy Osborne.

Wednesday, 1 March, 2006. Newton Lecture. Newton Medal Recipient: Richard Langton Gregory OBE FRS, University of Bristol ('Colours through a Bayes window'). A celebration dinner followed. Venue: City University, London. Organisers: Roy Osborne, John Barbur.

Tuesday, 13 March - Sunday, 28 April, 2006. 'Colour Group Artists Exhibition'. Exhibitors: Georgina Hunt, Stephen Shires, Margherita Abbozzo, Silvia Rizzo, F.H. Beaumont & Jules Davidoff, Michael Pickard, Roy Osborne, Lynn Bartlett. Venue: Institute of Physics, London. Organiser: Andrew Hanson. The Colour Group Artists was formed by Andrew Hanson, Jane Duncan and Bernard Staig-Graham at the Institute of Physics on 19 April, 2004.

Wednesday, 5 April, 2006. Joint meeting with the Institute of Physics. 'The 1931 Standard Observer'. Presenters: Andrew Hanson, National Physical Laboratory ('From the Greeks to 1931: a brief history of trichromacy'), Phil Green, London College of Communication ('Colorimetry in colour reproduction'), Boris Oicherman, University of Leeds ('CIE 1931 and the non-standard observers'), Michael Pointer, National Physical Laboratory ('CIE colorimetry: after 1931'). Venue: Institute of Physics, London. Organiser: Andrew Hanson.

Wednesday, 10 May, 2006. Annual General Meeting. Election of Dr Arthur Tarrant as Honorary Member of the Colour Group. Previous honorary members are John Guild, Walter Stiles OBE FRS, James Perry, Stanley Henderson, Brian Crawford, W. David Wright, R.G. Horner, John Holmes, Gordon Chamberlin, Roy Sinclair, Audrey Mitchell, Vernon Harrison, Robert Weale, Robert Hunt, John Hutchings, Margaret Halstead and Patrick Forsyth. Invited speaker: Jules Davidoff, Goldsmiths College, London ('The case against universal colour categories'). Venue: City University, London. Organiser: Lindsay MacDonald.

Wednesday, 14 June, 2006. Joint meeting with British Machine Vision Association: 'Colour in Vision Analysis'. Presenters: Roy Davies, Royal Holloway College, London ('Colour filtering: colour bleeding and related accuracy issues'), Adrian Evans, University of Bath ('Applying non-linear operations to multichannel images'), Dimosthenis Karatzas, University of Southampton, & Sophie Wuerger, University of Liverpool ('A hardware-independent colour-calibration technique'), Michael Pointer, National Physical Laboratory, et al ('Colour characterisation and calibration of a digital SLR camera'), Brahim Belem & Peter Plassmann,

University of Glamorgan ('A C++ colour space template library'), Stephen Westland, University of Leeds ('Colour assessment in dentistry'), Fred Stentiford, University College, London ('Attention-based colour correction'), Xianghua Xie & Majid Mirmehdi, University of Bristol ('Colour texture exemplars in the defect detection in random textures'), Lindsay MacDonald, London College of Communication ('Fatal flaws: uncertainty in the interpretation of colour in CCTV images'), Marilyn Sturgeon, NCS Colour Centre, Henley-on-Thames ('Case studies from the NCS Colour Centre'). Venue: London College of Communication. Organisers: Roy Davies, Lindsay MacDonald, Roger Bourdon.

Wednesday, 21 September, 2006. Joint meeting with Applied Vision Association: 'Colour and Animal Vision'. Presenters: Michael Land FRS, University of Sussex ('The eye movements in animals and man'), Robert Harris, University of Sussex ('Visual navigation and memory recall by ants'), Martina Wicklein, University College, London ('Strategies for colour learning in bees'), Hannah Rowland, University of Liverpool ('The cryptic value of countershading in Lepidopteran larvae'), Innes Cuthill, University of Bristol, et al ('Disruptive camouflage'), Christian Wehrhahn, University of Tübingen ('S-cones contribute to brightness perception in primates'), Jules Davidoff, Goldsmiths College, London, et al ('Cross-species differences in colour categorisation'), Tom Troscianko, University of Bristol, et al ('Bird and primate colour constancy'), Olle Hastad, University of Uppsala ('Phylogenetic distribution of colour-vision systems among birds'), Doekele Stavenga, University of Groningen ('Butterfly coloration and colour vision'), Ulrike Siebeck, University of Queensland ('Ultraviolet communication in reef fish'). Venue: University of Bristol (Department of Experimental Psychology). Organisers: Tom Troscianko, Daniel Osorio.

Wednesday, 4 October, 2006. 'Colour Teaching in Art'. Presenters: Roy Osborne ('Books on colour theory and a practical colour module'), Christopher Channing, Brent Arts Council ('Thoughts on teaching colour'), Jane de Saumarez, Open College of the Arts ('Warm and cool

primaries: colour mixing and contrast'). Venue: City University, London. Organiser: Roy Osborne.

Friday, 17 - Saturday, 18 November, 2006. Applied Vision Research Centre Symposium: 'Coloured Filters in the Eye: Protective Functions and Effects on Visual Performance'. Presenters: Robert Weale, King's College, London ('Optical colour filters: are they a benefit, a nuisance, or both?'), John Marshall, King's College, London ('Blue light as a co-factor or risk factor in AMD'), Dirk van Norren, University Medical Centre, Utrecht ('Optical density of the ageing human ocular media' & 'Choosing the optimal filter in an interocular lens'), John Barbur, City University ('Effects of ocular filters on visual performance in the mesopic range'), Marisa Rodriguez-Carmona, City University ('Contrast acuity thresholds, chromatic sensitivity and macular pigment optical density in the eye'), Billy Hammond, University of Georgia ('Macular pigment: compensation mechanisms and effects on visual performance'), Nigel Davies, Middlesex Hospital, London ('Does macular pigment have a role to play in age-related macular degeneration?'), Richard Bone, Florida International University, Miami ('Macular pigment optical density determined by reflectometry and flicker: is flicker the gold standard?'), Jack Moreland, Keele University ('Macular pigment measured by colour matching and by motion photometry' & 'Longitudinal stability of macular pigment assessed by minimum motion photometry: 4- to 8-year follow-up'), Tony Robson, Moorfields Eye Hospital, London ('Objective assessment of isoluminance at different eccentricities and estimation of macular pigment'), Tos Berendschot, University Eye Clinic, Maastricht ('Update on macular pigment and its relevance for age-related macular degeneration'), Christopher Hammond, St Thomas' Hospital, London ('A study of macular pigment supplementation: can we increase macular pigment optical density?'), Meike Trieschmann, St Franziskus Hospital, Münster ('Influences of supplementary lutein and zeaxanthin on macular pigment optical density and serum concentrations of these aryltenoids: The LUNA Study'), Melissa Liew, St Thomas' Hospital, London ('A twin study of macular pigment optical density'), John Mellerio, University of Westminster ('Macular pigment in two continents'), Max Snodderly, University of Texas ('Integrating macular pigment into retinal function'). Venue: City University, London. Organiser: John Barbur & the Applied Vision Research Centre. Sponsored by Bausch & Lomb, Cambridge Research Systems, DSM Nutritional Products, Essilor Ltd, the Colour Group.

Wednesday, 6 December, 2006. 'Bridging the Gap: Colour, Design, Total Appearance, Science and Expectations'. Presenters: Michael Pointer, University of Leeds ('Measuring appearance - what next?'), Stephen Westland, University of Leeds ('Interfacing design and technology'), John Hutchings ('Appearance and total appearance'). Venue: City University, London. Organisers: Roy Osborne, John Hutchings.

COLOUR GROUP SCHEDULE SPRING-SUMMER 2007

Wednesday, 10 January, 2007. Annual Vision Meeting and Palmer Lecture, Institute of Ophthalmology, London.

Wednesday, 7 February, 2007. Turner Lecture. Joint meeting with the Royal College of Art, London.

Wednesday, 4 April, 2007. Joint Meeting with Kenneth Craik Club, Gonville and Caius College, Cambridge.

Wednesday, 16 May, 2007. Annual General Meeting and Retiring Chairman's Address, City University, London.

Wednesday, 20 June, 2007. Joint meeting with the Computer Art Society, London.

Thursday, 12 July, 2007. Joint meeting with Institute of Physics, London.

ACKNOWLEDGMENTS

The Colour Group wishes to thank the City University, the National Physical Laboratory, the Institute of Ophthalmology, the Institute of Physics, the London College of Communication, the University of Bristol, the University of Westminster, the Royal College of Art, the University of Cambridge, the AIC, the ISCC, and Cambridge Research Systems.

HUNGARY

HUNGARIAN NATIONAL COLOUR COMMITTEE

BRIEF HISTORY

The Hungarian National Colour Committee has been founded in 1969. Its expert committees are as follows: Colour Classification, Coloured Vision, Colour Representation, Colour Measurement, Colour Environment Design, Colour Psychology, Colour Training, Colour Application. From 1980 on it operates within the framework of the Hungarian Academy of Sciences as an International Committee. From 1982 on some of its expert committees have founded independent societies. Hungarian National Colour Committee takes an active role in the life of AIC, from its foundation on: in 1 quadrennial cycle there was a Hungarian vice chairman, in 2 cycles there were 2 Hungarian members of the Executive Committee, there are members in all AIC Study Groups, and for 1 cycle we gave the chair for the Colour Education Study Group. AIC Midterm Conferences have been organized by us 3 times. The 7th Congress of AIC has been organized by us in Budapest.

EXECUTIVE COMMITTEE

Chairman:

Prof. Antal Nemcsics (Chair of Colour Science MTASzE)

Secretary:

Dr. János Zana

Members:

Prof. János Schanda (Chair of Society of Informatics MTAVEAB)

Mr. László Miskei (Chair of Color and Light Foundation SzFNA)

Prof. László Neumann

Prof. Ákos Nemcsics

Mr. Béla Tilless (Chair of Society of Fine Arts and Applied Artists MKISz)

Mrs. Ildikó Rozsovits

Mr. Árpád Szende (Chair of Colour Dynamics (ÉTESz)

Mrs. Ágnes Stáhl (Chair of Society of Coloristics (MKEK)

Prof. György Ábrahám

MEETINGS

International Conference on Colour Harmony, Budapest, Hall of the Academy of Sciences, April 24-26, 2007. Chairperson of Organisatory Committee: Prof. Ákos Nemcsics. Topics: theories of color harmony, colored vision, color preference, color harmonies in the design of color environment, in the architecture, in the fine arts, in the applied arts, in the industrial design, in the garden design, in the computer graphics. Number of participants: 105 persons from 23 countries. Read papers: 33, Poster papers 11. The papers are published on CD.

Symposium of Coloristics, Eger, Szent János Továbbképző Központ (Postgraduate Education Centre St. John), May 7-9. Chairperson of Organisatory Committee: Mrs. Ágnes Stáhl. Topics: colorimetry, development of color recipes, displaying colors, young researchers

introduces themselves by oral papers. Number of exclusively Hungarian participants: 88.

Lux et Color Vespremiensis, Veszprém, Pannon Műszaki Egyetem (Pannon University of Polytechnics), October 19. Chairperson of Organisatory Committee: Prof. János Schanda. Topics: color identification, information technology, investigation of light sources, color reproduction. Number of participants: 67.

Építészet és Művészet Szimpózium (Symposium of Architecture and Arts), Budapest, Hall of the Association of Hungarian Artists and Applied Artists, November 15. Chairperson of Organisatory Committee: Mr. László Miskei. Topics: Design of color appearance of Facades for reconstruction of historical city centres. Color usage of different historical ages, Color design methods. Number of participants: 89. The papers are published on CD.

BOOKS ON COLOR

Antal Nemcsics, *My travels in the realm of colour* (Budapest: Magyar Képek, 2007, ISBN 978 963 9439 52 8)

János Schanda, *Colorimetry: understanding the CIE system* (New York: John Wiley & Sons, 2007 ISBN 978 0 470 04904 4)

FUTURE ACTIVITIES

- Organisation and management of contextual negotiations related to post graduate color education and education for doctoral candidates held by different universities.
- Organisation of conferences for domestic audience.

CONTACT INFORMATION

Antal Nemcsics

nemcsics.antal@t-online.hu

ITALY

ASSOCIAZIONE OTTICA ITALIANA

BRIEF HISTORY

Since the late 1960s, the Italian Optical Association (AOI) is the AIC Italian member body. As a non-profit cultural association, the AOI's task is providing information about the state-of-the-art of light and images, both in research and application, as well as conferences occurring around the world. The spectrum of interests of the AOI is very broad, though in this report, it is limited to color science, color vision and related applications. Now, by monitoring the national situation across the past half-a-century, the AOI has been documenting not only the scientific and technical progress, but also the evolution of the attitudes of the involved people, by trying to adapt to the ineluctable changes of the concept of a "cultural, non-profit association."

ACTIVITIES

The AIC-related activities of the AOI may be subdivided into four groups:

1) **Educational.** Sergio Villani, the AOI President, is involved in courses organized in various parts of Italy dealing, in particular, with color vision and with the use of color in ophthalmology and optometry. L. R. Ronchi dealt with updating interested people in the new frontiers of visual science and color vision, in particular. Annotated bibliographies (see below) were distributed, free of charge, upon request. In particular, a relationship with architectural lighting was initiated by L. R. Ronchi, where she wrote a chapter on predictions at the design site in the "Handbook of Lighting."

2) **Organizing local meetings.** For instance, the AOI organized a cultural visit in Florence after request from the ECO (European Color Observatory, from Digione, France, www.eco-ca.fr). Amongst others, on the 11th June 2007 in the seat of AOI, Prof. Alain Bourgeois and two members of the staff of the ECO met three physicists, two architects, three teachers of the Academy of Fine Arts, and eight artists for an update in the science of color and visual Arts.

3) **Attending AIC meetings and color meetings sponsored by the AIC.** The International Conference on Color Harmony was held in Budapest, Hungary, April 24 – 26, 2007. Three Italians were members of the Scientific Committee: O. Da Pos, S. Rizzo, and L. R. Ronchi. Oral contributions were presented by Da Pos with Siviero, R. Pompas and S. Rizzo, the later also chairing a session dealing with color harmony in natural and rural landscapes.

The AIC 2007, "Color in Science and Industry", organized by the Zhejiang University at Hangzhou in China July 12 – 14, 2007, was attended by da Pos, R. Pompas (both, oral presentations), L. R. Ronchi (a poster), S. Rizzo (a poster) and Rita Rao, Editor of the Journal "Colore". Da Pos (member of the AIC Executive Committee) also chaired a Session, and L. R. Ronchi was invited to the stage with the other AIC past-presidents: A. Robertson, M. Ikeda, P. Alessi and the present president, J. L. Caivano.

4) **Initiating, encouraging, and supporting experimental research in color vision.** This is the case, for instance, of S. and L. Nucci, who consulted the AOI in the

matter of individual differences in the affective reactions, referring to the colors of the familiar objects, used in everyday life, and specifically relating to color naming (as displayed in a Poster proposed for the AIC2008).

Lastly, in color related activities to the CIE, O. da Pos, C. Oleari, L. R. Ronchi, and Giuseppe Rossi (INRIM, Torino) are members of the recently established CIE TC1-72, Appearance Measurement Network AMpNet, Chaired by Mike Pointer.

NEW INITIATIVES AND FUTURE ACTIVITIES

A new Interest Group has begun, devoted to a peculiar aspect of the visual process of color. The main topic is luminance and orientation; color is a feature extracted by the 1st order vision. Color cojoins with all the features of 1st and 2nd order vision (e.g., contrast, texture); however there are some cases where it does not follow the same rules of the other features. The interest group's aim is a better understanding.

An experiment was initiated, aimed at establishing a data set for various aspects of visual functionality involved by a response of 2nd order vision, known as visual balance, for both, spatially uniform and complex (paired) test objects. These take into account, in particular, the spatial distribution of color. A large number of observers is expected to take part in this project. Note that contrary to the responses of 1st order vision, a long perceptual training is needed for those of 2nd order vision, for example, visual balance.

A Study Group has begun, aiming at suggesting a model of the visual and non-visual, but eye-mediated effects of light. Distinction is being made between the effects (or responses) of first and second order, as is the case of computational modeling of vision. The "emotional" response to environmental lighting is officially regarded as an actual 2nd order response, and, first of all, a review of the available literature is needed.

In matter of future meetings:

- The ECO (European Color Observatory, Digione, France) is expected in Florence, in March 2008.
- Various Italians have been submitting Abstracts to the AIC 2008 in Stockholm.

RECENT PUBLICATIONS

L. R. Ronchi, *The Visual Process in the 3rd Millennium* (120 pages, in italian), Fond. G. Ronchi, Vol. XC, Florence, Italy, 2007.

L. R. Ronchi, "The Visual Process of the Color in the XXI Century," (104 pages, in italian), Fond. G. Ronchi, Vol. XCI, Florence, Italy, 2007.

LUCE, the Journal of AOI, a whole issue is devoted to the AIC 2007, Midterm Meeting, 12-14 July 2007, Hangzhou, China.

CONTACT INFORMATION

Associazione Ottica Italiana
1, Via Suor Maria Celeste
50125, Florence, Italy

FAX 0039. (055) . 22 20 90

E-mail(s) :

n.rositani@flashnet.it

lucia.ronchirostitani@associazioneotticaitaliana.info

prof.Villani@tin.it

Website:

www.associazioneotticaitaliana.info

JAPAN

THE COLOR SCIENCE ASSOCIATION OF JAPAN (CSAJ)

BOARD MEMBERS

[2006]

Shoji Tominaga (President), Takuzo Inagaki (Vice-President), Yasuhiro Nagata (Vice-President), Mituo Kobayashi (Chair of Kanto Chapter), Shin'ya Takahashi (Chair of Tokai Chapter), Haruyo Ohno (Chair of Kansai Chapter), Masao Inui, Mizue Kawamura, Fujio Maeda, Yoko Matsuda (Treasurer), Miho Saito (Treasurer), Masahito Suda, Takuzi Suzuki, Toru Yoshioka, Masayuki Inoue, Kazumasa Goto, Kenji Sugimoto, Noriko Takamatsu, Kazuyuki Natori (Treasurer), Yoshitsugu Manabe (Liaison with AIC), Masayuki Otake (Audit), and Hiroshi Komatsubara (Audit).

[2007]

Shoji Tominaga (President), Takuzo Inagaki (Vice-President), Yasuhiro Nagata (Vice-President), Mituo Kobayashi (Chair of Kanto Chapter), Shin'ya Takahashi (Chair of Tokai Chapter), Haruyo Ohno (Chair of Kansai Chapter), Masayuki Inoue, Kazumasa Goto, Kenji Sugimoto, Noriko Takamatsu (Treasurer), Kazuyuki Natori (Treasurer), Yoshitsugu Manabe (Liaison with AIC), Yumi Awano (Treasurer), Toru Ohzeki, Katsunori Okajima, Takashi Sakamoto, Reiko Tohyama, Hideaki Hayashi, Kazunari Morimoto, Hironobu Yoshikawa, Masayuki Otake (Audit), and Hiroshi Komatsubara (Audit).

MEETINGS

[2006]

The 37th annual meeting of the CSAJ was held at Kyoto Institute of Technology (Kyoto) on May 19 – 20, 2006. Participants in the meeting numbered about 300. Eighty-nine papers were presented from various fields of color science, design, and its applications. The invited lecture was given by Dr. Yoshimichi Ejima (Kyoto Institute of Technology) on "Color coding in the cortex –fMRI studies."

Color Forum Japan 2006 was held at Kogakuin University (Tokyo) on Nov. 27 – 29, 2006. Twenty-seven papers were presented.

[2007]

The 38th annual meeting of the CSAJ was held at The National Art Center, Tokyo (Minato-ku, Tokyo) on May 19 – 20, 2007. Participants in the meeting numbered about 330. Seventy-nine papers were presented from various fields of color science, design, and its applications. The invited lecture was given by Dr. Tetsuzo Kawamoto (Former President of L'Oreal Art & Science Foundation) on "Dynamics of Screenin : Issues on the evaluation of the L'OREAL Art and Science of Color Prize over the last decade."

Symposium on Color information in Nagano was held at Nagano University (Ueda, Nagano) on Sep. 7-8, 2007. Participants in the meeting numbered about 120. Fifteen papers were presented.

International Symposium on Vision and Image was held at Kogakuin University (Tokyo) on Oct. 26, 2007.

Color Forum Japan 2007 was held at Kogakuin University (Tokyo) on Nov. 27-29, 2007. Forty-four papers were presented.

AWARDS

2006 CSAJ Award: Munehira Akita (Emeritus of Kyoto Institute of Technology)

2006 CSAJ Research Encouraging Award: Nobuhisa Ochiai (Waseda University)

CSAJ Presentation Encouraging Awards 2006: Sho Kawamura (Nagoya University), Kumiko Miura (Waseda University), Ako Tsutsui (Joshi University)

2007 CSAJ Award: Hiroshi Kansaku (Emeritus of Chukyo University)

2007 CSAJ Research Encouraging Award: Hideki Sakai (Osaka City University)

CSAJ Presentation Encouraging Awards 2007: Norifumi Kunitomo (Keio University), Atsushi Kimura (Nihon University).

STUDY GROUPS

CSAJ has nine study groups: Color Design, Environmental Color, Illusion, Tutorial Materials for Color Education, Personal Color, Color Vision, Color in Image, Safety Color, and Color in Life.

PUBLICATIONS

Journal of the Color Science Association, volume 30, number 1-4 and Supplement, 2006 and volume 31, number 1-4 and Supplement, 2007 were published.

CSAJ News was published bimonthly.

CONTACT INFORMATION

The Color Science Association of Japan
3-17-42 Shimoochiai, Shinjuku, Tokyo 161-0033, JAPAN
Phone: +81-3-3565-7716
Fax: +81-3-3565-7717

MEXICO

THE MEXICAN ASSOCIATION OF COLOR RESEARCHERS

ASOCIACIÓN MEXICANA DE INVESTIGADORES DEL COLOR, AMEXINC

BRIEF HISTORY

Mexico is recognized around the world as a colorful country. Its people, food, clothes, houses, music and handicrafts express a richness of chroma. Yet, at present, there is no group of persons dedicated to enhancing this particular feature of Mexican culture.

The Mexican Association of Color Researchers (*Asociación Mexicana de Investigadores del Color*, AMEXINC), the only association of its kind in Mexico, was established May 2005 in Mexico City. Its main purpose is to research, teach, and promote knowledge about color throughout the Mexican Republic. At present there are visual artists, psychologists, physicists, graphic designers, and preschool teachers, among others, collaborating with AMEXINC. Indeed, this association is not only for academic researchers; it is open to all people with passion for color.

ACTIVITIES

The statutes of AMEXINC indicate a cultural commitment to society. For this reason, it has organized three seminars: periodic talks to the general public. In addition, AMEXINC has given informal talks in several different topic areas to students at various educational institutions. At the moment, these lectures have been given in the vicinity of Mexico City and in the state of Puebla. However, the aim is to expand these educational talks throughout the country.

In its first year, AMEXINC, in collaboration with TRILLAS, organized a cycle of talks and uploaded its webpage on the internet.

During 2006, the year of elections in Mexico, AMEXINC co-published *Toma y Lee*, a book about people's psychological color perception in relation to politicians' images which are conveyed unconsciously. Of particular interest is the article about the presidential candidates of the past election, entitled "*El color y los candidatos*" (Color and Candidates, Ortiz G. Toma y Lee). It is also worth mentioning that some members of AMEXINC participated in the ARGENCOLOR2006 Conference in Argentina, achieving many successes.

In 2007 AMEXINC developed new projects such as interdisciplinary research, continued talks and an ongoing information campaign in universities via e-mail and other media in order to promote the organization. A great accomplishment in 2007 was its membership to AIC.

For 2008, AMEXINC plans to offer courses in specific topics and to continue with talks at universities. Our web site will offer new services. The principal activity will be the organization of the first Mexican meeting of Color for May 2009. The call for papers will be released shortly.

Currently our members are carrying out research in colors as applied to education, colors and perception for visual arts and color properties of nanomaterials (photonic crystals).

EXECUTIVE BOARD

Georgina Ortiz (President)
Carlos I. Aguirre (Vice president)
Liliana Monroy (Secretary)
Alfonso de Lucas (Treasurer)
Iris Vergara (Web Site Designer and Honor Committee)
Martha Cuevas (Honor Committee)
Reyna Zapata (Honor Committee)

CONTACT INFORMATION

For more information, please visit our web page:
<http://www.amexinc.org.mx>

PORTUGAL

THE PORTUGUESE COLOUR ASSOCIATION

BRIEF HISTORY AND TESTIMONY OF THE PRESIDENT

The Portuguese Colour Association (Associação Portuguesa da Cor, APC) was founded in the context of the first edition of the Master Course in Colour in Architecture of the Faculty of Architecture at the Lisbon Technical University in 2003. In my capacity of author of the Master Course and its scientific coordinator, I invited researchers with noteworthy work in the area of colour to participate, namely Professor Byron Mikellides, Director of the Colour Research Section at Oxford Brookes University. The enthusiasm with which he lectured the module of Colour in Architecture and the many ways he stimulated the creation of the Colour Group were decisive in the process that culminated with the *encaenia* – the symbolic moment of the foundation of the Portuguese Colour Association – in his presence, on July 7, 2003 at the Faculty of Architecture in Lisbon. Due to the circumstantiality of contacts with the international community, this resulted in the invitation of other Professors: Jean-Philippe Lenclos, Frank Mahnke, and Luis Badosa, later joined by Pancho Miranda Guedes. The international appeal of the group was definitely established.

I would like to take this opportunity to thank, once again, Professor Byron Mikellides for his dedication and precious contributions. He promptly took the responsibility of addressing the first letter of recommendation in July 2003 to the president of the AIC, Paula Alessi, with his “blessing” for the Group in its application for AIC membership, and the other to the Vice-President at the time, Paul Green-Armytage, who wrote the other letter required by the AIC.

At the 10th International Congress of the AIC (8 –13 May, 2005) that took place in Granada, the Portuguese Colour Association was accepted as a regular member to the AIC by unanimous vote of the Executive Committee.

It is now our duty to fulfil and to honour the recognition of the merit of the Portuguese Colour Association with work of quality, within this space of communication and collaboration that was given for us to build in the present and for the future.

Prof. Dr. Maria João Durão

ACTIVITIES

The activities carried out by the APC include conferences and seminars, professional and educational activities as well as colour interventions carried out by members. The academic research is highlighted with a range of themes for master and doctoral degrees, as well as research projects in partnership with the ColourLab of the Faculty of Architecture.

The research focus of the founding members has been expanded through the influence of the new members to embrace a variety of fields, from architecture and design to philosophy, psychology and the neurosciences. With new technologies and materials, the potential use of colour in architecture has been enhanced and colour and light have become a field of experimentation using multiple approaches, whatever the scale of the object of study.

Light and shadow are vehicles of communication of meanings, symbols, and expressions that vary according to context, typology of reflected light and the quality of lighting that dislocate as membranes on the surface of the terrestrial globe and depend upon geographic and cultural contexts. Therefore, the activities carried out by the PCA members acknowledge the value of the multiplicity of experiences and explore the fertile fields of colour in the quest for understanding the transformation of the material substance (lumen) to spiritual substance (lux).

PROJECTS DEVELOPED WITH THE COLOURLAB

“Colour perception in parietal ceramic cladding: a transcultural study of colour perception for urban space,” Carla Lobo, Maria João Durão, ESAD-Escola Superior de Arte e Design, Fábrica Molde, Revigrés.

“Colour lexicon,” Maria João Durão, João Pernão, Catarina Costa, Carla Lobo, Instituto Piaget, Faculdade de Arquitectura de Lisboa, Faculdade de Belas Artes de Lisboa, ULHT, Escola Superior de Arte e Design, Caldas da Rainha.

“Ergonomics of web colour: interface versus user,” Ana Sofia Romão Louro, Maria João Durão. Participants: Faculdade de Arquitectura de Lisboa, da Universidade Lusófona de Humanidades e Tecnologias, IADE.

“Colour studies of the historic centre of Oporto,” Helena Soares, Jean-Philippe Lenclos, Atelier 3D, Luís Bissau, Fernando Caria, Maria João Durão.

ARCHITECTURAL COLOUR PLANS

“Colour plan–urban rehabilitation of the Alagoas quarter in Régua, IHRU Institute of Habitation and Urban Rehabilitation 2007,” José Aguiar, Maria João Durão, João Pernão, Helena Soares.

“The colour plan for the Bo’ness harbour bridge 2007,” Royal Haskoning Architecten Amsterdam (Joris Smits and Filipa Santos, Architects).

“Colour plans for the conservation and rehabilitation programme of the municipality of Lisbon 2004/2006,” Luis Bissau.

“Colour plans for the municipality of Lisbon « Lisbon in colour » 2004/2006,” Luis Bissau.

“Colour plan for the interior spaces of the Hospital de Santo André in Leiria 2007,” João Pernão, Luis Bissau, Diana Soeiro.

PHD RESEARCH PROJECTS IN DEVELOPMENT

“Colour as shelter: Architecture as care,” PhD in Philosophy, Faculty of Social and Human Sciences, Universidade Nova de Lisboa: Diana Soeiro.

“Colour in the city, a factor for signalling, orientation and identification,” PhD in Design, Faculty of Architecture, Lisbon Technical University: Margarida Gamito.

“Colour in exterior Azulejo’s Cladding: A cross-cultural study on colour perception in urban environment,” PhD in

Design, Faculty of Architecture, Lisbon Technical University: Carla Lobo.

“The interpretation of reality through colour: measurement, registration, analysis, and application of psychometric data for the establishment of chromatic invariables in perception,” PhD in Architecture, Faculty of Architecture, Lisbon Technical University: João Pernão.

“Visual communication and inclusive design: colour and legibility on posters and the aged vision,” PhD in Design, Faculty of Architecture, Lisbon Technical University: Cristina Pinheiro.

MASTER DISSERTATIONS AND PUBLICATIONS

Master Degrees in “Colour in Architecture” (Faculty of Architecture-Lisbon Technical University) obtained with the following unpublished Master Dissertations (2005-2007)

Carla Lobo, “Matéria, Brilho e Cor: Características do Azulejo e sua importância na percepção espacial: Para uma reabilitação do azulejo como elemento qualificador do espaço público urbano” [Matter, brilliance and colour: azulejo’s (tile’s) characteristics and its relevance in special perception – towards a rehabilitation of the azulejo (tile) as a qualifying element in the urban public space].

Margarida Gamito, “A Cor na Formação do Designer” [Colour for Design Education].

Luisa Marques Martinez, “Cor e Conceito em Arquitectura – Um estudo da obra de Pancho Guedes” [Colour and Concept in Architecture – A study of Pancho Guedes’ work].

André Mesquita, “Cor e Sistema Efêmero-A Teoria Cromática de Le Corbusier e a sua Aplicação na “Unidade de Habitação de Marselha” [Colour and Ephemeral System- Le Corbusier’s Colour Theory a its Application to “L’Unité d’Habitation de Marseille”].

João pernão, “A interpretação da realidade como variação da cor pela luz no espaço e no tempo” [the interpretation of reality as colour variation due to light in space and time].

Cristina Pinheiro, “A gestão da cor na habitação social – Lisboa séc. XXI” [The colour management in social housing – Lisbon XXI Century].

Zélia Simões, “A Cor e a Natureza como Metáforas na Poética da Materialidade” [Colour and Nature as Metaphors in the Poetics of Materiality].

Felipa Benito-Garcia Paes de Vasconcellos, “A Cor como poder transformador do Espaço : Um estudo sobre a utilização activa da cor, na manipulação de espaços expositivos interiores” [Colour as a Spatial Transformation Power- A study on the active use of Colour in the manipulation of interior exhibitional spaces].

Santos, Ana Filipa Vieira, “Mutações de Ambientes através da Luz e da Cor” [Ambient Mutations through Light and Colour].

PUBLICATIONS

Durão, M. J. (2006) “Funções perceptuais para o design de espaço”. *Caleidoscópio: Revista de Comunicação e Cultura*. 6. Pp 155-167.

Durão, M. J. (2006). “O Diáfano e o μέλας”. *Ar - Cadernos da Faculdade de Arquitectura da Universidade Técnica de Lisboa*. 6. Pp 144-147.

Durão, M. J. (2006). *Colour and Space*. Lisboa: Dislivro.

Durão, M.J. (2007). “Colour Research in the APC: Colour and Light Resonating Architecture-Transcultural Studies”. *VIII Congreso Nacional del Color* . Museu Casa de la Moneda, Madrid.

Durão, M.J. (2007). “Sensory perspectives: Colour”. In Barrett P. & Barrett, L. *Senses Brain and Spaces Workshop Report: The Think Lab, University of Salford*. Salford Centre for Research and Innovation in the Built and Human Environment Edition.

Durão, M. J. & Vasconcelos, M. C. (2007). “Research in Art and Design: A common ground between science and creative practice”. *International Association of Societies of Design Research Proceedings*. Hong Kong: Hong Kong Polytechnic University.

Durão, M. J. (2007). “Sketching the Ariadne Thread for Alchemical Linkages to Painting” , *FABRIKART-Arte, Tecnología, Industria, Sociedad*, nº7, Ed. Universidad del País Vasco-Euskal Herriko Unibertsitatea.

Pernão, J. N. & Durão, M. J. (2006). “Elementos para um novo entendimento da cor como geradora do espaço e do tempo”. *Artitextos*. Dez. 3. Pp 149-178.

COURSES

Prof. Dr. Maria João gave a course on Colour within the module “Anthropology of Vision” at the post-graduate level for the Master Degree Course in Design at the Faculty of Architecture, Lisbon Technical University in 2006 and 2007.

The Architect Zélia Simões was invited to lecture on the “Theory of Colour” in the Course of Post-Graduation in Graphic Arts at the Instituto Superior de Educação e Ciências-ISEC in 2006 and the module “Form and Colour” at the Escola Superior de Tecnologias e Artes de Lisboa in 2007.

The Architect João Pernão lectured on “Light and Colour” at undergraduate level at the School of Architecture of the Faculty of Architecture Lisbon Technical University in 2006 and 2007.

Designers Margarida Gamito and Cristina Pinheiro taught the discipline “Chromatic Analysis” at the undergraduate course of Design, IADE-Institute of Visual Arts, Design and Marketing Lisbon in 2006 and 2007.

The Designer Carla Lobo taught colour in the discipline “Design, Ceramics and Glass” at the Escola Superior de Arte e Design in Caldas da Rainha, Leiria College of Art and Design in 2006 and 2007.

CONFERENCES AND SEMINARS

Bissau, Luis “Cor Urbana” (Urban Colour), Exponor-Concreta, organized by ROBBIALAC, Porto, 22 Oct. 2007.

Durão, Maria João “Colour Research in the APC: Colour and Light Resonating Architecture-Transcultural Studies”, *VIII Congreso Nacional del Color*, organized by the Instituto de Física Aplicada and Sociedad Española de Óptica, Museu Casa de la Moneda, Madrid, 19-21 Sep., 2007.

Durão, Maria João “Research in Art and Design: A common ground between science and creative practice”, IASDR Conference *Emerging Trends 2007*, organized by the *International Association of Societies of Design Research*, The Hong Kong Polytechnic University, 12 – 15 Nov., 2007.

Durão, Maria João “Sensory perspectives: Colour”. Senses, Brain and Spaces Workshop, organized by the Think Lab, affiliated in ANFA-*Academy of Neuroscience for Architecture*, The University of Salford, Manchester, U.K., 8-9 Mar., 2007.

Pernão, João, “A percepção da cor no espaço e no tempo”, organized by the Ordem dos Arquitectos, Casa Municipal da Cultura Fernando Távora, Aveiro, 13 Jul., 2007.

ACADEMIC SEMINARS

Pinheiro, Cristina, “Cor no espaço urbano e nos bairros sociais”, Seminar within the module of Antropologia do Espaço, Universidade Lusíada – Lisboa, Jan., 2006.

Pinheiro, Cristina, “Cor no espaço”, Seminar integrated in the “Semana de Projecto”, IADE-Instituto de Artes Visuais, Design e Marketing, Lisboa, Maio, 2006.

Gamito, Margarida, “A cor na formação do designer” Seminar integrated in the “Semana de Projecto”, IADE-Instituto de Artes Visuais, Design e Marketing, Lisboa, Maio, 2006.

Pernão, João, “A interpretação da realidade pela cor”, Seminar integrated in the module of Análise Cromática, IADE-Instituto de Artes Visuais, Design e Marketing, Lisboa, 9 Feb., 2007.

Pernão, João, “Luz e cor”, Escola de Artes-Leiria, 5 May, 2007.

HONORARY MEMBERS

After having distinguished Professor Byron Mikellides as our first honorary member for the reasons addressed in the History section of this report, the APC is proud to communicate the addition of four more honorary members: Professors Pancho Miranda Guedes, Jean-Philippe Lenclos, Frank Mahnke and Luis Badosa, for their outstanding work in the field of colour as well as the significant contributions they made to the establishment of the Associação Portuguesa da Cor in their dedication to the founding members.

WEBSITE AND NEWSLETTER

The biography and resumé of the honorary members can be found on our site.

A detailed content of this report is published in the Newsletter and posted on the website www.apcor.org.

WEBSITE

Since 2007 the website has new functions, a broader range of content, and a bilingual format (Portuguese and English).

We welcome all links with national and international colour communities.

Editorial coordination: Luis Bissau

Web design: Zélia Simões

NEWSLETTER

Editor: Maria João Durão

Collaborators: Carla Lobo

João Pernão

Margarida Gamito

Graphic design: Helena Soares

APC OFFICERS

President: Maria João Durão

Vice-President: Luís Bissau

Secretary: João Pernão

Treasurer: André Mesquita

Director: Margarida Gamito

AUDIT COMMITTEE

Chairman: António Bica; Directors: Helena Soares; Luisa Marques

Officers of the General Meeting

Chairman: Felipa Vasconcelos; Secretaries: Cristina Pinheiro; Verónica Conte

CONTACT

Prof. Dr. Maria João Durão

Associação Portuguesa da Cor

Faculdade de Arquitectura de Lisboa

Rua Sá Nogueira, Pólo Universitário Alto da Ajuda

Lisboa, 1349-055 - Portugal

+351 213615089

mjdurao@fa.utl.pt

www.apcor.org

SLOVENIA

DRUSTVO KOLORISTOV SLOVENIJE SLOVENIAN COLORISTS ASSOCIATION

BRIEF HISTORY

The Slovenian Colorists Association (SCA) is concerned with staff education, seminar organization, distribution of monographs, participation in international conferences and activities, and solving member's problems.

REGULAR ACTIVITIES

Staff education,
Organisation of 15th anniversary of the Slovenian Colorists Association,
Publishing of the monograph "Contribution to the Slovenian Treasure of Colour Knowledge,"
Exhibition "15 years of SCA," held in Maribor, Celje,
Distribution of the monograph, "Intedisciplinarity of Colour Parts 1 and 2,"
Participation in international meetings,
International activities,
Solving of membership problems,
SCA homepage.

ORGANISATION OF 15TH ANNIVERSARY OF SLOVENIAN COLORISTS ASSOCIATION, SEPTEMBER 2007

The main activities were conducted to the preparation of 15th anniversary of SCA activity. The organization committee prepared the following programme:

Greeting of the SCA president and the patron agency for research of the Republic of Slovenia,
Invited lecture by Dr. Manuel Melgosa, University of Granada, Spain entitled, "A trip from colour terms to color emotions,"
Introduction to the chronology of SCA,
Presentation of the publication, "Contribution to the Slovenian Treasure of Colour Knowledge,"
Recognition granting,
Exhibition "15 years of SCA."

The celebration took place at the University of Maribor library on September 28, 2007. The Welcome followed the lecture of Dr. Manuel Melgosa, then, an introduction to the chronology of the SCA. From the presentation, the successful work of the Slovenian Colorists Association on domestic and international environment was verified.

The publication "Contribution to the Slovenian Treasure of Colour Knowledge" included first the description of the association roots, which began during the 1980's. The chronological presentation of SCA activities followed and at the end, the bibliography of SCA members.

During the festive celebration, the SCA granted the members of the SCA initiative committee and founders of SCA, Department for Textiles NTF University of Ljubljana and Department of Textile materials and design FS University of Maribor. The conclusion followed the opening of the exhibition, "15 years of SCA."

The exhibition included 19 glass cases and four panels showing the foundation documents, SCA roots, important members (prof. dr. Anton Trstenjak and prof. dr. Vera Golob), domestic activities (seminars, exhibitions, publications, lectures), excursions, international relations (membership, agreements – AIC, DFZ, DfwG, IFATCC, foreign publications), international symposia Colour and Colorimetry, Color and Textiles, Color of national symbols, Color and Coatings, etc. The M.Sc. and Ph.D. diplomas were presented and also the Slovenian Center for colour and dyeing.

We ended the celebration with a festive dinner. Dr. Manuel Melgosa also gave a lecture in Ljubljana at the Department for Textiles. The lecture was titled "What is new in industrial color-difference evaluation."

ORGANISATION OF THE INTERNATIONAL MEETING COLOUR AND COATINGS, NOVEMBER 2007

The SCA Section for Coatings organized the international symposium Colour and Coatings, which was held November 15 – 16, 2007 in Bled. The programme included 17 lectures of foreign and domestic experts and the main focus was the exchange of ideas and opinions.

INTERNATIONAL AND DOMESTIC ACTIVITIES

SCA renewed the activities of the SCA Commission for International Cooperation. It was proposed that Prof. Dr. Marija Gorenšek become a member of the scientific committee of IFATCC scientific committee. Prof. Dr. Majda Sfiligoj presented an invited lecture. Our members are active participants in many international symposia and other foreign events.

In the domestic field SCA has also organized and promoted the exhibition of the students of the Textile department (course graphic technology) of the Faculty of Natural Sciences of University of Ljubljana under the mentorship of Sabina Bračko, Ph.D. Presentations were made on the development of Slovenian national symbols and their color evaluation. The exhibition was in the University of Maribor Library (January 2007) and in The museum in Celje.

SLOVENIAN COLORISTS ASSOCIATION

Vetrinjska 16
2000 Maribor
Slovenia
www.dks-drustvo.si

President: prof.dr. Slava Jeler, slava.jeler@uni-mb.si
Vice president: prof. dr. Marija Gorenšek,
Marija.gorensek@ntf.uni-lj.si
Treasurer: Vera Mavrin
Secretary: Dunja Legat, legat@uni-mb.si

SPAIN

COMITÉ ESPAÑOL DEL COLOR

THE COLOR COMMITTEE OF SPAIN (OPTICAL SOCIETY OF SPAIN)

ACTIVITIES

A new board emerged from the past VIII National Meeting on Optics (Alicante, 19-22 September 2006) where a new Vice President (President-elect) and Secretary were elected. From here, we again want to thank to Dr. Jaume Pujol, as Past-President, for the leadership, work and impetus developed along these years for the progress of our national committee.

Undoubtedly during 2007, the main event for our Committee was the organization of the 8th National Congress (Madrid, September 19-21), chaired by Dr. Joaquín Campos (Instituto de Física Aplicada, CSIC), which took place in the Museo Casa de la Moneda (Fábrica Nacional de Moneda y Timbre, see http://www.fnmt.es/en/html/sd_re.asp). Detailed information about this meeting can be consulted in the website: <http://www.metrologia.csic.es/viiicnc/index.htm>. This meeting had an audience of 142 assistants, 14 of which belonged to the staff of Fábrica Nacional de Moneda y Timbre, the headquarters of the congress. It was also reported that 20 students were awarded with scholarships consisting of a fee discount. Moreover, the Congress was sponsored by 16 prestigious companies. As for the scientific output of the congress, 40 oral presentations were presented, together with six invited lectures and 46 posters. The inaugural lecture was presented by Dr. Franz Hengstberger (current President of CIE), “*The role of CIE as an international standards organization in the field of Photometry and Colorimetry.*” Other invited lectures were given by the following speakers: Mr. Karl Johan Bertilsson (from the Scandinavian Colour Institute Ab.) with the subject “*La importancia de una comunicación del color precisa y comprensible para todos*”; Prof. José María González Cuasante (from University Complutense of Madrid) with the subject “*Amarillo y Azul: Primarios Sustractivos y Complementarios Aditivos. ¿Verde o Gris?*”; Dr. Maria Durao (from UTL, Portugal) with the subject “*Research Developed within the Portuguese Colour Association APC*”; Mr. Luis Borrueal (from Fábrica Nacional de Moneda y Timbre) with the subject “*Propuestas de Gestión de Color en la FNMT*”; and, Prof. José Manuel Sánchez-Pena (from University Carlos III in Madrid) with the subject “*Color y discapacidad*”.

A workshop of the Spanish network on Color Science and Technology chaired by Dr. Joaquín Campos (CSIC), was held in Madrid past 18-19 April, 2007:

http://www.metrologia.csic.es/color_imagen.html. This meeting included an invited lecture by Prof. Jussi Parkkinen (from the Joensuu University, Finland) with the title “*Different possibilities of spectral colour science.*” This meeting was clearly oriented to boost the participation and training of our PhD students and the communication of the different research groups of this scientific network. It was completed with 11 oral presentations, almost all in the English language, distributed among the research groups belonging to CSIC (Madrid), University of Granada (UGR), Technical University of Catalonia (UPC), and University of

Alicante (UA). All contributions in this meeting have been published in the book entitled “*Ciencia y Tecnología del Color. Seminario 2007 de la Red Temática*” (Eds. Dr. Joaquín Campos Acosta and Dr. Rafael Huertas Roa, ISBN: 84-96856-31-3).



Official photograph (with about 60% of attendants) of the 8th National Congress on Color (Museo Casa de la Moneda – Fábrica Nacional de Moneda y Timbre, C/ Doctor Esquerdo 36, Madrid, Spain). In the center of the first row, from left to right: Dr. Javier Romero (AIC Secretary - Treasurer), Dr. Franz Hengstberger (CIE President), and Dr. Joaquín Campos (current President of the Color Committee of Spain, and General Chair of the Organizing Committee of this congress).

Different members of the Color Committee of Spain have participated as invited speakers, session chairs, and members of the Scientific Committees of different color meetings: AIC 2006 Interim Meeting (Johannesburg, South Africa, 24-27 October 2006), 26th CIE Session 2007 (Beijing, China, 4-11 July, 2007), AIC 2007 Interim Meeting (Hangzhou, China, 12-14 July, 2007). In addition, researchers from our National Committee have participated in some CIE Technical Committees, in particular CIE TC 1-57 (Standards in Colorimetry), CIE TC1-71 (Tristimulus Integration) and CIE TC8-11 (CIECAM02 Mathematics).

On the other hand, the Color Group of the Technical University of Catalonia (<http://www.cd6.upc.edu/>), conducted by Dr. Jaume Pujol, and with the support of our national committee, will organize in June 2008 the 4th European Conference on Color in Graphics, Imaging and Vision (CGIV) in Terrassa (Barcelona, Spain) (<http://www.imaging.org/conferences/cgiv2008/>).

Finally, it deserves to remark the active participation of the Color Group of the University of Granada, together with the Universities of Saint Etienne (France), Joensuu (Finland), and Gjøvik (Norway), in the European Master Erasmus Mundus “Color in Informatics and Media Technology” (CIMET), which will start next September 2008. For additional and updated information on this postgraduate course you are kindly invited to visit

<http://www.master-erasmusmundus-color.eu/>. Moreover, another postgraduate course on “Photometry and Color Technology” is also being organized by the National University of Tucumán (Argentina), Technical University of Catalonia (UPC), and University of Alicante for the forthcoming academic year 2008-09, from a previous format available in

http://www.ua.es/dpto/dofa/postgrado_color/tecnologiadelcolor.htm.

EXECUTIVE COMMITTEE

Dr. Joaquín Campos Acosta (CSIC), President.

Dr. Jaume Pujol (Universidad Politécnica de Cataluña),
Past-President.

Dr. Manuel Melgosa (Universidad de Granada), President-elect.

Dr. Francisco Martínez-Verdú (Universidad de Alicante),
Secretary.

WEBSITE

For additional and updated information on the activities of our Committee you are kindly invited to visit <http://sedoptica.cfmac.csic.es/color/color.html>.

SWEDEN

STIFTELSEN SVENSKT FÄRGCENTRUM SWEDISH COLOUR CENTRE FOUNDATION

HISTORY

In 1964, the Swedish Colour Centre Foundation was founded by the IVA (Royal Academy of Engineering Sciences), the Swedish Design Council, and industry. The goal was to carry out interdisciplinary research and development within the colour field. Dr. Anders Hård, the creator of the NCS system, was appointed to lead the work together with well-known colour researchers such as Dr. Lars Sivik (psychology) and Prof. Gunnar Tonnquist (physics) and, of course, Prof. Sven Hesselgren and many other influential architects, designers, teachers and industrial personalities.

The task of the Swedish Colour Centre Foundation today is:

- to encourage scientific research within the colour field of interest for industry, education, and people working with colour,
- to spread new knowledge and experience within the field of colour, and
- to be a natural centre for colour and colour research.

COLOUR DAY 2007

The Swedish Colour Centre Foundation arranges annual colour conferences to spread knowledge and use about colour, always with an actual theme. The Colour Day 2007 having the theme, "The Colours of the Future from Idea to Reality," attracted more than 200 participants on November 20, 2007. The moderator of this year's Colour Day was Ewa Kumlin, Managing Director of the Swedish Society of Crafts and Design. The Colour Day 2007 was an experience in colour and light shows, in interesting talks, in inspiring exhibitions and in delicious food.

Two international lecturers were invited:

Per Arnoldi is a Danish painter, graphic artist, sculptor and designer. He is well known for his bright and clear colours. He has been colouring and decorating a number of buildings designed by the British architect Norman Foster. The name of his talk was, "When colour communicates." The other international lecture was given by Gottfried Pank, futurist and creative director for mode...information, Germany. He is a well-known speaker worldwide about coming trends within fashion and design. He talked about "Signs of the times – the forces that drives trends."

We also listened to talks about the interaction between colour and lighting, colour and pattern in textile design, and the importance of getting the "right colour" in industrial design. Will it ever be the right colour? In the conference room we also had the opportunity to see an exhibition from our sponsors. This inspiring exhibition was designed by some young design students.

MEMBERS' MEETINGS

In January 2007, that year's first meeting, we did a study visit to the Swedish Society of Crafts and Design where we listened to a talk by Ewa Kumlin, the Managing Director. She has a lot of colour experiences from the entire world.

In March we visited an exhibition and discovered one part of the Swedish cultural history at "Nordiska Museet," Sweden's largest museum of cultural history. This time it was an exhibition of old Swedish wallpaper.

In May we did another study visit, this time to the studio and home of Åke Axelsson. He is one of the most well-known furniture and interior designers in Sweden.

The next study visit, in September, took us to the home Carl Linnaeus, because of the Linnaeus Anniversary Year 2007. The contributions made by Carl Linnaeus (1707-1778) to Systematic Botany have probably made him the best-known Swede in the world. His system of classifying plants gained him a great reputation. The system was first presented in 1735 in his famous work, "Systema Naturae." His home is newly restored and is decorated with a lot of hand painted wall papers.

In December our annual meeting in the Swedish Colour Centre Foundation was held. The guest speaker Richard Sexton, English artist, gave us a very interesting talk about the cultural and symbolic meaning of blue, "The story of blue in Art and culture."

THE FUTURE

During 2007, a couple of workshops have been arranged by The Swedish Colour Centre Foundation with the aim to discuss our possibilities to expand, and to gain and inspire new members. Our activity plan, which stretches from 2002 to 2008 includes our vision, goals, and targets for the acquisition of new members. We are constantly working with and updating this plan so that we may be able to reach our goals.

The planning of the AIC Interim Meeting 2008 "Colour – Effects and Affects," which will be held in Stockholm is now going on in full activity. Please visit our homepage for latest information! www.aic2008.org

CONTACT INFORMATION

Berit Bergström
Secretary
berit.bergstrom@ncscolour.com

SWITZERLAND

SWISS COLOUR ASSOCIATION, PRO/COLORE

Colour plays an important role in different sectors of the Swiss economy, e.g., in graphic design, architecture, industry, textile industry and other fields including the broad public sector. The Swiss colour association *pro/colore* aims to serve as a general and professional platform for dealing with colour design, dyes, colour reproduction, colour communication and other areas of concern with colour. One of the signers of the founding act of the International Colour Association (AIC), *pro/colore* has been a member of this organization since the AIC's founding in 1967.

The past year resulted in many interesting events, as well as contacts with experts in different business sectors concerned with colour in Switzerland and beyond.

NEWLY-ELECTED *PRO/COLORE* PRESIDENT



At last year's General Assembly on March 29, 2007, Ernesto Bergantini (St. Gallen) was nominated and unanimously elected as the new President of *pro/colore*. He began his term as of April 2007. Ernesto Bergantini is a Textile Designer, Head of the Colour Design Course and Professor at the Swiss University of Applied Sciences in St. Gallen. Already a member of the *pro/colore* Executive Board until 2004, Bergantini succeeds Daniel Pfeffer (Zurich), who served as *pro/colore* President for the last four years (2003-2007). As listed below, Daniel Pfeffer will continue as a member of the *pro/colore* Executive Board. In addition to his engagement with *pro/colore* Daniel Pfeffer is a representative of both the Swiss Research Centre for Rationalization in Building and Civil Engineering (CRB), as well as the Natural Colour System (NCS) Colour Centre Switzerland.

The renewal of the Executive Board was also on the agenda at the annual General Assembly. Previous members who will continue for a further period of office include:

- Markus Christen, CEO *Philips AG Lighting* Switzerland
- Christian Engi, Textile Designer, *Engi Design*
- Verena Felder, Designer, *Felder Designs*
- Kirsten Domdey, Interior Decorator, *Sto AG* Switzerland
- René Oeschger, Rep. Head of Educational Centre, *Swiss Association of Painters and Plasters (SMGV)*
- Ueli Wagner, Architect, *HNW Architects*
- Brigitta Weber, CEO, *Hurter Wallcoverings AG*
- Daniel Pfeffer, Head Marketing Services, *CRB*

A successor still has to be found for long-time Executive Director Simone Hensch. Since August 2007 colour designer Eveline Staub has assumed this function for *pro/colore*. Ms. Staub has maintained her own painting studio for more than fifteen years. She has participated for many years in the colour events organized by the German colour association *Deutsches Farbenzentrum*. In addition, she works full-time as an event manager for a major Swiss life insurance company. Parallel with the changeover of the executive director position, *pro/colore* has a new address, as provided at the end of this report.

EVENTS 2007

The host of the 2007 General Assembly, as well as of the following first *pro/colore* meeting in March 2007, was the firm *Zumtobel Licht AG* in Zurich, an internationally leading supplier of complete systems and advanced lighting solutions. Carina Buchholz, head of the lighting showroom, convincingly demonstrated how a unique custom application can be generated by combining technology, design, emotion and energy efficiency. All of those present could sensibly and palpably experience the fascinating impact that changes of colour and intensity in artificial light can have. See also www.zumtobel.com.

At the second *pro/colore* meeting in June 2007 *Expomobilia AG* and *Techno Fot AG* in Effretikon demonstrated that there are no limits concerning the effects of colour in exhibition and fair design. *Expomobilia AG* is not only one of the biggest exhibition and fair design companies in Switzerland, but is also well-established in Europe, America and Asia. *Techno Fot AG* specializes in large-scale digital reproductions. Visiting these firms, *pro/colore* members were also impressed by the ease of the collaboration that guarantees the positive performance of both firms in the market. See www.expomobilia.com and www.technofot.ch.

In September 2007 the next host of *pro/colore* was the firm *Geberit Vertriebs AG* in Jona. Since 1874 *Geberit* has been one of the true pioneers in sanitary technology. Offering universal system solutions, again and again *Geberit* continues even today to be a trendsetter. The main topic of the guided tour was "The Ideal Restroom Facility – Quiet Place with Resonance." Christof Hindermann, designer and interior architect, presented the "spectacular experience restroom" that his design firm *designrichtung GmbH* in Zurich has designed and realized. On the one hand, the aim was to show the most frequent omissions and oversights

usually performed in the design of a restroom, a typically ‘neglected’ space; and, on the other hand, possibilities of atmospheric enhancement using simple means as well as the technical innovations of the *Geberit* firm were presented. The glass façade and entrance hall of *Geberit*’s main building have also been recently renewed with an appropriate and contemporary appearance. Thereby the detailed explanation of the design, conceptual and planning procedures was extremely interesting. See www.geberit.com.

The fourth *pro/colore* meeting was scheduled to take place in November 2007 under the title “Making Decorative Effects Using Enamel Finishes.” The intended host was the firm *Rupf + Co. AG* in Glattbrugg. Unfortunately the event had to be cancelled. *pro/colore* hopes that this topic can be discussed soon in an upcoming meeting. See www.ruco.ch.

On March 3, 2008, the first *pro/colore* meeting will take place in Basel. The *Museum der Kulturen* (Museum of Cultures) will guide the *pro/colore* participants through the exhibition “Red – Hot on the Trail of a Colour.” Extraordinary correlations between life and death, power and aggression, symbolism, religion, identity, design and much more are expressed by using the colour red. See www.mkb.ch.

CONTACT INFORMATION

www.procolore.ch

Pro/Colore, Head Office
Ms. Eveline Staub
Postfach 8701
CH-8036 Zurich
Switzerland
Tel. +41 44 342 36 08
Fax +41 44 342 36 09
E-mail: info@procolore.ch

Pro/Colore, President
Mr. Ernesto Bergantini
Turnerstrasse 33
CH-9000 St. Gallen
Switzerland
Tel. +41 79 474 83 57
E-mail: ebergantini@stfschule.ch

UNITED STATES OF AMERICA

INTER-SOCIETY COLOR COUNCIL (ISCC)

BRIEF HISTORY

The ISCC is the principal professional society in the field of color in the United States. The Council was founded in 1931 with the goal of advancing the knowledge of color as it relates to art, science, and industry. There are three classes of ISCC membership: Individual, Member-body, and Sustaining. There are currently 15 Sustaining Members, 18 Member-Bodies and approximately 550 Individual Members. The ISCC website is www.iscc.org.

PUBLICATIONS

The ISCC publishes a newsletter six times each year. It also offers the following technical reports: *Color and Light* by Fred W. Billmeyer Jr. and Harry K. Hammond III; *Demystifying Color* by Robert Chung; Proceedings of the 9th Congress of the International Colour Association, Rochester, NY, June 2001; and *Guide to Material Standards and Their Use in Color Measurement* (ISCC TR-2003-1).

MEETINGS

The Inter-Society Color Council had two successful meetings in 2007. The first was a Special Topics meeting on Industrial Color Challenges, co-sponsored with the AATCC, one of the Council's member bodies. The meeting was held February 22-23 in Charlotte, North Carolina. Of the almost 90 attendees, the largest single group were the representatives of merchandisers, such as Macy's and JCPenney (both companies presented papers), who sit between designers and suppliers and whose job is to insure the consistency of color goods sourced across a global supply chain.

The second meeting was our Annual Meeting, held April 29-30 in Kansas City, Missouri. The meeting was organized around the theme of "Bridging the Creative and Production Sides of Color." This theme was a natural fit for the Council and its aims. It was well developed by the presentations at the meeting, including the keynote talks from Hallmark Cards that covered color creativity, trends, and reproduction. Hallmark, headquartered in Kansas City, was one of the three new sustaining members in 2007: the other two were Avian Technologies and Xerox.

The closing keynote at the Annual Meeting was delivered by Robert W. G. Hunt, who received the 2007 ISCC Godlove Award "for his many seminal contributions to color science and color metrology, for his development of models of color appearance and for his efforts towards the education of generations of color scientists and technologists." Also at the meeting, David Wyble received the ISCC Nickerson Service Award for his contributions as

the ISCC Webmaster. The Abstract Book from the meeting is available as ISBN 978-1-4242-4273-0.

UPCOMING EVENTS

The ISCC looks forward to 2008. The Council is planning its Annual Meeting in Baltimore, September 14 and 15, followed by a one-day Safety Color Expert Symposium. Later in the fall, there will be a Special Topics meeting on November 15 in Portland, Oregon, following the Color Imaging Conference. The theme of the meeting is "Black and White," two of the most important colors in any imaging application and critical in the graphic arts workflow.

AWARDS

The ISCC presented the 2006 Macbeth Award for recent outstanding achievements in the field of color to Dr. David Brainard of the University of Pennsylvania. Dr. Mary McKnight, formerly of NIST, received the Nickerson Service Award.

The ISCC is soliciting nominations for the 2007 Godlove Award. The Godlove Award honors long term contributions in the field of color and is the most prestigious award bestowed by the ISCC.

ELECTIONS

Joining the ISCC Board in 2007 were Barbara Parker from JDS Uniphase, David Hinks from North Carolina State University, and Cameron Miller from NIST.

IN MEMORIAM

Sadly there was the loss of Sandy Austin, who passed away in December, midway through her term on the Board. Two long-time supporters of the ISCC also passed away in 2007: Ralph Stanziola, who was an Honorary Member of the Council and recipient of the ISCC Nickerson Award in 2004, and Therese Commerford, who was also an Honorary member and the ISCC Secretary from 1982 to 1990.

PROJECT COMMITTEES

The ISCC currently has two Project Committees: #52 – Comparative List of Color Terms II, chaired by Ellen C. Carter, and #54 – Colors of Maximum Contrast, chaired by Hugh S. Fairman and Ralph Stanziola.

CONTACT INFORMATION

Dr. Robert Buckley
ISCC President 2006-2008
Robert.Buckley@xeroxlabs.com

REPORT FROM THE AIC STUDY GROUP ON COLOUR EDUCATION

The Study Group on Colour Education of the International Color Association (AIC) is an international network of scientists, teachers within the field of colour (colour theory, colour design, colour psychology etc.) and other professionals such as designers and architects with a specific interest in colour education. The aims are the exchange of knowledge and experiences among its members; the stimulation of teaching and research; to inform about coming congresses, seminars, workshops and exhibitions that might be of interest for the members of the group; and to share with other members news from congresses, seminars, workshops, publications, and exhibitions.

PROJECTS AND ACTIVITIES

The study group has its own Newsletter with news and information about coming AIC meetings and other colour seminars, colour studies, methods of teaching colour, new literature etc. Members are very welcome to contribute to this newsletter.

We also have a literature list which is continuously updated regarding literature, reports and research papers regarding how colour is used in colour studies and about how to teach colour.

Our list of literature used in colour education is divided into the following groups:

- Colour Atlases, Systems and books about them
- Literature about how to teach colour
- Papers about how to teach colour
- Literature and papers that we use to teach colour
- Journals
- Video
- CDROM

A Bibliography of Books on Colour 1500-2000: 2,500 Titles in English & Other European Languages by Roy Osborne has also been forwarded to all members.

During the AIC Midterm Meeting 2007 in Hangzhou there were no specific paper presentations regarding colour education, but there was time set up for a meeting of the Study Group.

PROJECT ABOUT CHILDREN AND COLOUR

In the study group there is an ongoing project, "Collection and analysis of colour books for children." This project will inquire into how children get in touch and learn about colour beginning with their earliest exposure. The project is addressed to all members from different countries. It is understood as a comparative and intercultural study.

A questionnaire, forwarded to all members, is divided in the following three parts:

- A) About teaching and learning in schools,
- B) Investigating and analysing of the materials and tools available in public and private schools,
- C) Authorship and books for children.

These kinds of projects are very important for the Study Group. This will attain the goal of the Study Group to be a natural worldwide network for colour education, and that can only happen when everyone is active.

EMAIL

The Study Group CE has following e-mail address:
swedish.colourcentre@ncscolor.com

MEMBERS OF THE STUDY GROUP ON COLOUR EDUCATION

The Study Group has now 66 members, and 30 nations are represented in the group. The member list is not on our web site to avoid excessive spam. It will be sent out continuously when new members are being introduced.

The membership is free, and is available for every person/organization who/which scientifically or practically deals with colour in colour education, contributes to the realization of the aims mentioned above to support the Study Group generally. The requisites for being incorporated as a new member of the Colour Education Study Group are to subscribe and participate in the e-mail list and to have presented a paper or poster at an AIC meeting

CHAIR

Berit Bergström, Swedish Colour Centre Foundation,
PoBox 49022, S-100 28 Stockholm, Sweden
Phone: +46 8 617 47 00. Fax: +46 8 617 47 47

REPORT FROM THE AIC STUDY GROUP ON ENVIRONMENTAL COLOUR DESIGN

HISTORY

On the occasion of the Fourth AIC Congress in Berlin in 1981, Antal Nemcsics (Hungary) proposed the creation of a study group for colour dynamics that was finally consolidated at the AIC Interim Meeting in Budapest in the following year, as the "Study Group on Environmental Colour Design." Anders Hård (Sweden) served as the first chairman, and Lars Sivik (Sweden) as its first secretary. In 1989, Leonhard Oberascher (Austria) succeeded as chairman. A small group within the ECD Study Group, which included the chairman, Lars Sivik, Werner Spillmann, and Paul Green-Armytage, established new objectives. The main aim was to disseminate knowledge and experience gained in the process of integrating colour in planning, designing, and realizing the built environment. A second important objective was to communicate the evaluative experiences of environmental colour design. The means of exchange were to be meetings, a newsletter, and collaboration with other groups and organizations. In the period between 1998 and 2005, José Luis Caivano (Argentina) was chairman and Leonhard Oberascher co-chairman.

AIC 2007 MIDTERM MEETING IN HANGZHOU, CHINA

The meeting of the AIC Study Group on Environmental Colour Design (ECD) was held at the AIC 2007 Midterm Meeting in Hangzhou, China, in the Bauhinia Hall of the Dragon Hotel, on Friday, July 13th, 4:00-5:20pm, together with the AIC Study Group on Colour Education.

The agenda of the ECD Study Group included the following:

- 1) Objectives of the ECD Study Group,
- 2) Presentation of the new ECD logo,
- 3) Presentation of the new ECD web site,
- 4) Members of the ECD Study Group,
- 5) Subscribers of the Colour Mailing List,
- 6) Progress Report of the ECD Project "Interaction of Colour and Culture. Environmental Colour Design 1900-2010: An Anthology on Colour."

Twenty-seven participants attended the AIC Meeting, thereby 8 members. Co-chair Leonhard Oberascher was unfortunately not able to attend the AIC Meeting.

OBJECTIVES

The main aim of the ECD Study Group is to disseminate knowledge and experience gained in the process of integrating colour in planning, designing, and realizing the built environment. A second important objective is to communicate the evaluative experiences of environmental colour design.

LOGO

The ECD logo is intended to give an identity to the Study Group, and indicate as well, its relation to the AIC. The logo design is a product of the collaboration of the Atelier Cler

Paris and diaphan gestaltung Zurich. Two participants wish to submit variations of the presented logo.

WEBSITE

A new website has been needed since the election of the new chair. The idea is to have an operative website in order to communicate with members and provide frequently updated news. Therefore, *ad chroma* (a Paris based association founded in 2003) will be hosting the new website for the ECD Study Group. Previously, it was hosted by the Faculty of Architecture at the University of Buenos Aires at <http://www.fadu.uba.ar/sitios/sicyt/color/e.cd.htm>. A website presentation of the ECD Study Group will be included in the AIC website, as suggested by Jose Luis Caivano and Paula Alessi during the meeting, and a link to this new website will be provided. It is important to host the new website at *ad chroma* where it can be easily updated by the ECD chair.

MEMBERS

Currently, the ECD Study Group has 81 members, including the 19 new members who joined the ECD Study Group in Hangzhou. Our members are working in such diverse countries as Argentina, Australia, Austria, Belgium, Brazil, Canada, P. R. China, Finland, France, Great Britain, Greece, Hong Kong, Hungary, Iran, Italy, Japan, Korea, Norway, Peru, Poland, Slovenia, Spain, Sweden, Switzerland, Thailand, Turkey, and the USA. Anyone can become a member of the AIC Study Group on Environmental Colour Design. The only requirements are: 1) to have participated via an oral presentation or poster in at least one of the last four AIC Meetings or Congresses; 2) to subscribe to the colour mailing list and participate in the informal discussions on colour.

COLOUR MAILING LIST

The current colour mailing list color@fadu.uba.ar has 228 members. Informal discussions on topics relating to colour in general, and environmental colour design in particular are welcome. Any interested person can join the colour mailing list and thereby receive information and participate in the online discussion.

To join, please send an email to: majordomo@fadu.uba.ar The subject heading must be left blank. The body of the email should only include this line: subscribe color <your e-mail address> To unsubscribe the line is: unsubscribe color <your e-mail address>

PROGRESS REPORT OF ECD PROJECT

The current project of the ECD Study Group was launched at the AIC Interim Meeting in Johannesburg, South Africa. Its title is: INTERACTION OF COLOUR AND CULTURE. Environmental Colour Design 1900-2010: An Anthology on Colour. The aim of the project is to collect published and unpublished texts, articles and essays from many different countries written by practitioners such as architects, landscape architects, colour consultants, artists,

designers, graphic designers, cultural heritage commissioners, urban designers, town planners and lighting designers, as well as other professionals who have been directly involved in the conception, realization and application of colour in the environment and urban space.

The goal of the project is to make the historic and actual texts available in the form of an Anthology on Environmental Colour Design. Many key texts on colour remain unknown for a variety of reasons, e.g., they are unpublished; or, published in journals that are now out-of-print; or, they are simply difficult to access or have appeared in a fragmentary form in texts on the general theory of architecture, art and design. Therefore, the plan is to include 1) papers from past AIC Meetings, 2) articles and papers not available in some countries for different reasons, 3) texts available only in one language (unless the single language is English).

Collecting and publishing these texts together will not only serve to validate individual efforts and achievements, but also put these in an historical context. This will serve the broader aim of promoting a deeper understanding of the relevance of colour in the overall design process of the twentieth and early twenty-first centuries. As a result, a basis for trans-national discussions concerning a cross-cultural appreciation of environmental colour design will be established.

The current texts are coming from Argentina, France, Germany, Norway, Russia, South Africa, Sweden, Switzerland, and...

Please send us your contribution now!
ecd.studygroup@yahoo.com or vmschindler@yahoo.com

CHAIR

Verena M. SCHINDLER (Switzerland / France)
AIC Study Group on Environmental Colour Design
Email: ecd.studygroup@yahoo.com or
vmschindler@yahoo.com

REPORT FROM THE AIC STUDY GROUP ON VISUAL ILLUSIONS AND EFFECTS

WHY A STUDY GROUP ON VISUAL ILLUSIONS

Visual illusions are so attractive that nowadays many people considerable time studying them and inventing new illusions for their own and others' fascination. Visual illusions are exploited in many ways both in art and in industry, and many publications find their fortune in their illusory appeal. People are even willing to pay for admiring illusion exhibitions.

HISTORY

The International Association of Colour (AIC) has within its scopes the task of spreading and promoting the study of colour in all its multi-faceted aspects. Among the visual illusions in general, colour illusions play a specific role as colour is the core of all vision. Inside the AIC, the Study Group on Visual Illusions and Effects was established in 1993 in Budapest with the aim of promoting studies and uses of colour illusions.

THEORY

The most popular concept of illusion derives from the direct experience we undergo when something happens against our expectations, implying that in some particular cases, our expectations are wrong. Scientific knowledge is considered a fundamental and reliable source of expectations, but we can make mistakes naturally and therefore, the illusions we encounter can be caused by incorrect reasoning; in parallel some people think that illusions depend on some defective perceptual mechanism. Other times the illusory outcome is just contradicting our knowledge of the real physical world and this is enough to induce us to think the illusion is a case in which our perception does not conform to reality. All these interpretations are quite common, as even in the well-known site, <http://illusioncontest.neuralcorrelate.com/>, it was proposed that "visual illusions are those perceptual experiences that do not match the physical reality." The conclusion seems unavoidable. "Our perception of the outside world is generated indirectly by brain mechanisms, and so all visual perception is illusory to some extent" (ibidem).

In the best case the reason for the illusion would rest in some malfunctioning of our perceptual system and therefore, "the study of visual illusions is of critical importance to the understanding of the basic mechanisms of sensory perception, as well as to cure many diseases of the visual system."

Alternatively, when we experience illusions our feeling is different from when we have normal perceptions, and we distinguish rather well between the two situations. Therefore, there must something relevant differentiating them. According to our psychological approach, illusions are cases in which an object or event, perceived as the same object/event (in weaker cases, only known as such), appears surprisingly different in different viewing conditions. The basic ideas of this theory were discussed in an AIC Conference in Kyoto (1997), reported in the proceedings

and later developed both in the theory and in experiments. The study of scientific contributions presented in the AIC meetings (as reported in the AIC Newsletter) revealed that most illusions are simply due to our limited scientific knowledge. As soon as our knowledge of the specific context is more correct, the illusion disappears. Nevertheless, there are still many cases of old and new illusions that resist our explanations, and these cases are strongly attracting the general interest of layman and scholar.

UPCOMING MEETING IN STOCKHOLM

An overview of some most significant colour illusions will be given with the aim of showing their peculiar characteristics in the theoretical framework described above.

A new proposal will be presented for the more engaging AIC Conference in Sidney 2009.

CHAIR

Prof. Dr. Osvaldo da Pos
Department of General Psychology
University of Padua
Via Venezia 8
35131 Padova
ITALY
Tel: +39 049 827 6680
Fax: +39 049 827 6600
Email: osvaldo.dapos@unipd.it

REPORT FROM THE AIC STUDY GROUP ON COLOUR PERCEPTION OF THE ELDERLY

PURPOSE

The purpose of this Study Group (SG) is to discuss and share information on the basic and practical studies about the colour perception of the elderly, such as colour appearance, colour discrimination, brightness perception of colours, colour preference, and application tools for planning and testing universal colour designs.

ACTIVITIES

Some SG members presented papers at international meetings and published papers appropriate research journal in 2007:

Katsunori Okajima and Shin-nosuke Fujimoto, "Influence of Spatial Frequency Distribution in Brightness Perception of Light Environment," Perception 36 Suppl., 81 (2007).

M.Ayama, H.Ujike, M.Funakawa, W.Iwai and K.Okajima; "Effects of Contrast and Character Size upon Legibility of Japanese Text Stimuli Presented on Visual Display Terminal," Optical Review, 14, 48-56 (2007).

Some SG members were invited as guest speakers at "The Third Vision Science & Technology Symposium," held in Toyohashi, Japan on December 16, 2007.

The chairman and the secretary of the SG discussed the future planning on the SG and held a private seminar at the University of Granada, Spain.

HOME PAGE

The homepage of the SG (<http://www.cpesg.org>) restarted recently because the server had been down caused by virus attacks. Only registered members who have an ID and password can see the homepage and get variable information on aging vision research. The mailing-list system for the SG is under reconstruction because the server was attacked and knocked out by a large number of virus emails.

MEMBERSHIP

Currently, the number of members is 65 from 14 countries.

FUTURE ACTIVITIES

- We will enrich the homepage contents steadily.
- We will fix the mailing-list system as soon as possible and make an effort to issue the mailing news periodically.
- We will expand our activity in "Colour Universal Design" field.
- We are planning to hold a symposium at AIC2009 in Australia.

CHAIR

Katsunori Okajima, Ph.D.

Yokohama National University
Japan
Email: okajima@ynu.ac.jp

Secretary:
Manuel Melgosa
University of Granada, Spain

REPORT FROM CIE DIVISION 1

This report is a brief summary compiled from the January 2008 Activity Report. The summary will be limited to color. See <http://www.cie.co.at/div1/>.

OFFICERS

Director: Prof. Ronnier Luo (GB)
Assoc. Director - Vision: Dr. Miyoshi Ayama (JP)
Assoc. Director - Color: Dr. Ellen Carter (US)
Editor: John Setchell (US)
Secretary: Dr Michael Pointer (GB),
mrpointer@btinternet.com

DIVISION 1 MEETING IN BEIJING, CHINA

The annual meeting of Division 1 was held as part of the CIE Quadrennial Meeting, on Tuesday, 10 June 2007 in Beijing, China. The meeting was attended by 5 Division officers, representatives of 19 of the 37 member countries, 20 TC chairs and reporters, and about 30 guests.

The following Technical Committees met in Beijing:

TC1-42 Colour Appearance in Peripheral Vision
TC1-44 Practical Sources for Daylight Colorimetry
TC1-56 Improved Colour Matching functions
TC1-58 Visual Performance in the Mesopic range
TC1-61 Categorical Colour Identification
TC1-63 Validity of the Range of CIEDE2000
TC1-65 Visual Appearance Measurement
TC1-68 Effect of Stimulus Size on Colour Appearance
TC1-69 Colour Rendering of White Light Sources

ACTIVE TECHNICAL COMMITTEES,

COLOR SECTION

TC1-27 (C) Specification of Color Appearance for Reflective Media and Self-Luminous Display Comparison

Year Established: 1990

Terms of Reference:

To study and make recommendations for the specification of a color appearance match between a reflective image and a self-luminous display image.

Chairman: PJ Alessi US

TC1-44 (C) Practical Daylight Sources for Colorimetry

Year Established: 1995

Terms of Reference:

1. To compare existing daylight simulators for color measuring instruments and colour matching booths.
2. On the basis of this intercomparison, to recommend practical methods for simulating daylight sources.

Chairman: R. Hirschler HU

TC1-55 (C) Uniform Color Space for Industrial Color Difference Evaluation

Year Established: 1999

Terms of Reference:

To devise a new uniform color space for industrial color-difference evaluation using existing experimental data.

Chairman: M Melgosa ES

TC1-56 (C) Improved Color Matching Functions

Year Established: 1999

Terms of Reference:

1. To compare results based on the current CIE color matching functions, color matching functions proposed by Dr. W. Thornton's laboratory, and those of CIE TC1-36. 2. To initiate experiments to obtain data for such comparison in different laboratories. 3. To report to CIE Division 1 on the results of the above investigation and make an eventual recommendation for future CIE color matching functions. 4. To report to CIE Division 1 an eventual recommendation for the use of the new color matching functions in specifying color spaces and color-difference formulas.

Chairman: M Brill US

TC 1-57 (C) Standards in Colorimetry

Year Established: 2000

Terms of Reference:

To prepare a series of CIE/ISO/IEC Standards that describe: 1. The method of calculating CIE tristimulus values and chromaticity co-ordinates. 2. A uniform colour space and its associated metrics. 3. A formula for industrial colour difference evaluation

Chairman: AR Robertson CA

TC1- 61 (C) Categorical Color Identification

Year Established: 2001

Terms of Reference:

To prepare a report describing a color categorization map for the photopic and mesopic illumination levels.

Chairman: T Ishida JP

TC1- 62 (C) Color Rendering of LED Light Sources

17

Year Established: 2002

Terms of Reference:

To investigate by visual experiments color rendering properties of white LED light sources and to test the applicability of the CIE color rendering index to white LEDs.

Chairman: P Bodrogi, HU

TC1- 63 (C) Validity of the Range of CIEDE2000

Year Established: 2003

Terms of Reference:

To investigate the application of the CIEDE2000 equation at threshold, and to CIELAB colour differences greater than 5 units.

Chairman: K Richter, DE

TC1- 64 (C) Terminology for Vision, Color, and Appearance

Year Established: 2003

Terms of Reference:

To monitor the terminology requirements of Division 1 including the revision of the present ILV terms and the addition of new terms.

Chairman: S. McFadden, CA

TC1-65 (C) Visual Appearance Measurement

Year Established: 2003

Terms of Reference:

To study, develop, and recommend a soft-metrology framework for measuring visual appearance. This should include potential measurement areas, psychophysical procedures and real applications.

Chairman: M R Pointer, GB

TC1-66 (C) Indoor Daylight Illuminant

Year Established: 2004

Terms of Reference: To prepare a CIE recommendation on an Indoor Daylight Illuminant and a corresponding Indoor Daylight Source, considering the needs of the partner international standards organizations.

Chairman: J. Schanda, HU

TC1-68 (C) Effect of Stimulus Size on Color Appearance

Year Established: 2005

Terms of Reference: To compare the appearance of small ($<2^\circ$) and large ($>20^\circ$) uniform stimuli on a neutral background.

Chairman: Peter Bodrogi (HU)

TC 1-69 (C) Colour Rendition by White Light Sources

Year Established: 2006

Terms of Reference:

To investigate new methods for assessing the colour rendition properties of white-light sources used for illumination, including solid-state light sources, with the goal of recommending new assessment procedures.

Chairman: Wendy Davis (US)

TC 1-70 (C) Metameric samples for indoor daylight evaluation

Year Established: 2007

Terms of Reference: To investigate the derivation of a set of metameric samples to enable the evaluation of indoor daylight simulators.

Chairman: B Kranicz (HU)

TC 1-71 (C) Tristimulus Integration

Year Established: 2007

Terms of Reference:

To investigate methods for computing weighting tables for the calculation of tristimulus values from abridged data.

Chairman: C Li (CN)

TC 1-72 Measurement of Appearance Network: MApNet

Year Established: 2007

Terms of Reference:

1. To establish a network of those interested in the measurement of visual appearance. 2. The network shall be under the direction and guidance of a group of at least four Technical Leaders each responsible for a particular aspect of the subject. 3. Each Technical Leader shall provide substantial periodic reports in a form that might be published. 4. A second Expert Symposium on Appearance shall be organised at an appropriate time within the next 4 years. 5. A database of relevant published work shall be maintained. 6. Consideration shall be given to the establishment of separate Technical Committees when appropriate.

Chairman: MR Pointer GB

REPORT FROM CIE DIVISION 2

Yoshi Ohno from NIST (USA) started acting as Division 2 Director at the CIE quadrennial meeting held in Beijing last July. T. Goodman (former Director) was enthusiastically thanked by the new management team and the participants for her excellent leadership for Division 2 for the past eight years. Goodman will remain on CIE Board as Vice President Publication for the next term.

The main news from the technical committees (TCs) are the following. (For reports of each TC, see the minutes of the meeting at the Division 2 Web site: <http://cie2.nist.gov/>).

DISSOLUTION OF TCs AND REPORTERSHIPS:

TC2-42 "Colorimetric measurements for visual displays" was closed due to inactivity. Related activity will continue under a new reportership.

R2-28 "Evaluation of colorimeter spectral responsivity" was closed due to inactivity for several years.

R2-37 "Industrial lighting requirements for a D65 illuminant": A report was submitted in 2006 with no TC proposal, and activity completed.

NEW TCs AND REPORTERSHIPS

ESTABLISHED:

TC2-62 Imaging-photometer-based Near-Field Goniophotometry. Chair: Walter Steudtner (Germany). TR: To prepare a CIE recommendation on the methods for

characterization and calibration of imaging-photometer-based near-field goniophotometers and for determination and conversion of photometric data of lamps and luminaries for both near-field and far-field applications.

R2-38 Measurement of spectral properties of photometers and colorimeters. Reporter: Jianguan Pan (China). TR: Investigate the measurement conditions for spectral responsivity of colorimeters and photometers, with special account for determination of f_l .

CHANGES OF TCs AND REPORTERSHIPS:

The TR of TC2-51 (Calibration of multi-channel spectrometers) is changed. New TR: Produce a technical report for the calibration of detector array spectroradiometers primarily for the determination of colorimetric and photometric quantities, including performance characteristics, evaluation of these characteristics, calibration methods and guidance in the application of methods for the determination of uncertainty.

FUTURE D2 MEETINGS AND SYMPOSIA:

The next D2 meeting will be in Torino, Italy, hosted by M. L. Rastello. In conjunction, a D2 symposium on advanced photometer, colorimeter, and spectral measurements will also be held. See <http://www.inrim.it/CIE2008/>.